

## Operating instructions and spare parts list

DOK-271-GB.doc

Rev. 1

**designation**

**airless spray appliance**

**type**

**30-50**

**Order-No.: 7240-000**

- keep for further use -

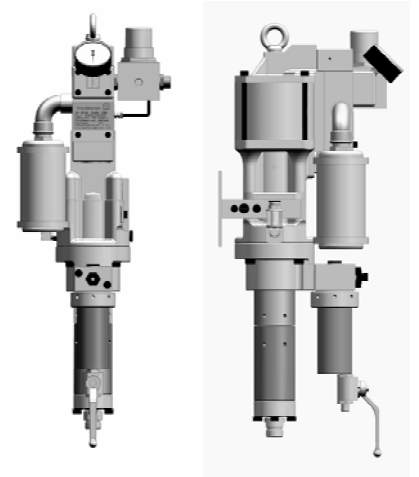

**Krautzberger**

## The Airless process

Atomization and agent application are brought about without the use of air, thus the term Airless. The agent is being atomized by squeezing it under an extremely high pressure through the small bore of the material nozzle. In the process the agent is disintegrated into individual particles.

The pressure required for the Krautzberger Airless process may attain up to **480bar** and is generated by compressed air operated positive-displacement piston pumps.

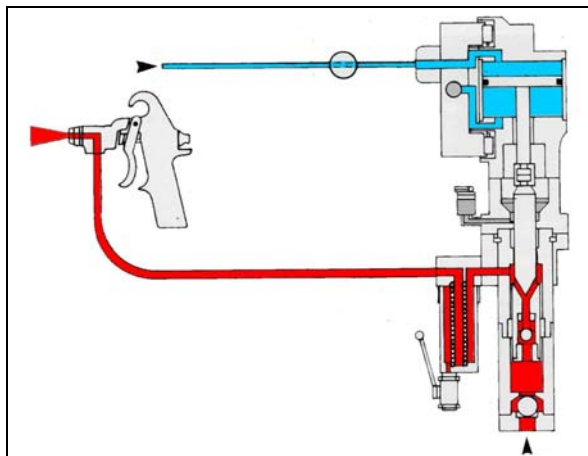

### Advantages of the Airless spray

- upgraded spray performances
- instant surface coating due to a full and saturated homogeneous spray pattern and instant film formation
- reduced spray time
- increased material yield due to minimized spray fogs and low material rebound.
- fatigueless working brought about by a light and handy spray gun design equipped with only on material supply hose
- optimized atomisation even of high viscous materials

## 1 Method of operation of the positive-displacement pump

By means of an independently controlled air motor which is alternately applying pressure onto the motor piston, the recuperator piston of the pump is moved upwards and downwards.

Air motor and recuperator piston are interconnected via an coupling system.

Whilst moving upwards the suction valve is opened and the agent is sucked into the lower chamber of the hydraulic unit. Simultaneously the pressure valve located in the piston is being closed and the recuperator piston feeds the agent into the hydraulic unit.

The set spray pressure and the adopted nozzle size determine the stroke frequency, the air consumption. and thus the respective spray performance of the positive-displacement pump.

All agent conveying pump components consist of special steel 18/8

Bezeichnung	HD-Pumpe
Typ	30-50
Artikel	7240-000

## 2 Mounting and installation

### Installation-plan

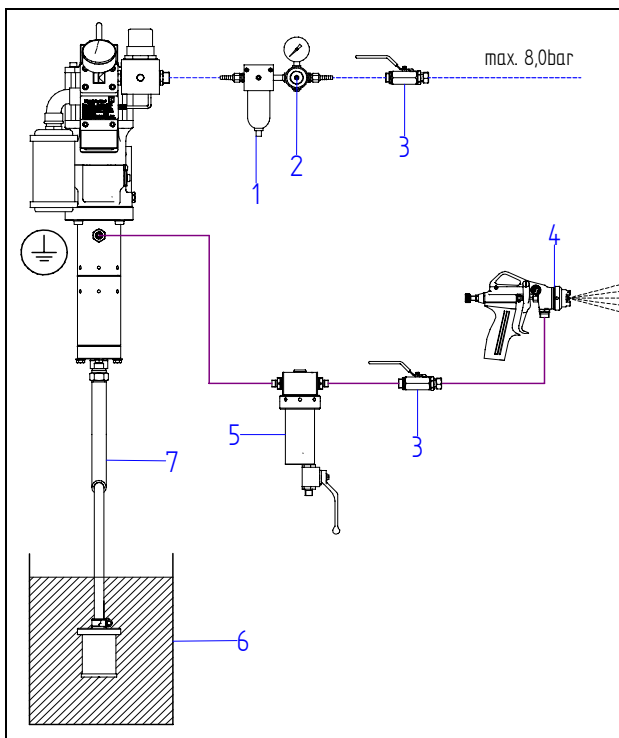

1	Oil- /water separator
2	Pressure regulator
3	Ball valve
4	Spray gun
5	Filter
6	container
7	Suction hose

The Airless pump is to be installed in such a way as to render it easily accessible for maintenance and cleaning purposes.

The pump holder is provided with an earthing screw to which the ground wire must be connected in order to ground the static charge generated by the agent flowing within the hose.

Connect the Airless pump only with a heavy duty compressed-air supply net:

designed for a maximum compressed air consumption.

PRIOR TO START-UP, CLOSE THE PRESSURE REGULATOR OF THE AIRLESS PUMP BY COUNTER-CLOCKWISE TURNING THE HAND-WHEEL.

The piping supplying compressed air to the Airless-pump should have a nominal width of 9.

**Furthermore we recommend to provide the compressed air supply net with an oil- and water separator in order to prevent foreign bodies from penetrating into both air motor and independently operating control system.**

If need be a compressed air-oiler with deicing agent maybe installed between airless pump and oil/water separator.

Use only the original suction gear in order to ensure proper pump sucking.

Engage spray gun's safety catch and connect the material supply hose at the outlet of the high-pressure filter.

WHEN IT COMES TO MATERIAL SUPPLY HOSES WITH SAFETY CONDUCTOR IN ORDER TO PREVENT ELECTROSTATIC CHARGES FROM BEING GENERATED.

### CAUTION:

With regard to operating the Airless pump we prefer to the safety rules edited and published by the applicable employers liability insurance.

## 3 Start-up

- Entirely close pressure regulator at motor
- connect compressed air-hose (max. 8bar)
- in case the pump is provided with a material filter, (strongly recommended by us) a filter mesh matching the nozzle

Bezeichnung	HD-Pumpe
Typ	30-50
Artikel	7240-000

requirements must be used. See table

- Fill rinsing agent into the rinsing chamber, until the sight glass shows a 70% fillin level
- Slowly open pressure regulator until air motor starts working.
- Rinse the Airless pump by means of the rinsing agent in order to get the preservatives out of the pump
- put the suction hose into the spray agent
- open spray gun in order to evacuate the air still contained in the system
- When the spray agent starts to emerging from the spray gun, close spray gun and set the required working pressure at the pressure regulator (max 8bar)

**CAUTION!**

**PAY ATTENTION TO THE PRESSURE TRANSFORMATION RATIO!**

Under no-load conditions the Airless-pump must only be operated for a short time and at a slow running level.

Otherwise motor, suction valve, piston valve and the pump sealing may be damaged.

**CAUTION!**

The spay jet emerging from the spray gun is dangerous. For this reason aim the spray gun only downwards.

## 4 Switching off

Switching-off

- Entirely close pressure regulator at motor

- disconnect spray gun and render the system pressureless.
- remove and clean the spray nozzle
- remove suction hose out of the spray agent and put it in a thinner
- slowly open pressure regulator whilst the spay gun is being opened, until the air motor starts working
- rinse spray gun and pump by means of a thinner. In the process make sure that the motor runs at a slow level only
- for rough cleaning of the filter during rinsing , shortly open the cock at filter

### Maintenance

Daily check rinsing agent level during operation. Sight glass must show a 70% filling level.

In case the rinsing agent is contaminated by the spray agent, replace the rinsing agent. If, after a short time only, the rinsing agent should again be contaminated or should the rinsing agent level displayed by the sight glass increase, we recommend to replace the gasket set, item 22 and item 30.

By replacing these gasket sets, the recuperator piston prevented from being worn out prematurely.

We recommend to open the material filter at fixed intervals in order to clean the filter housing, mesh inclusive.

**CAUTION!**

Prior to opening material filter refer to instructions

## 5 Technical data

### Air consumption

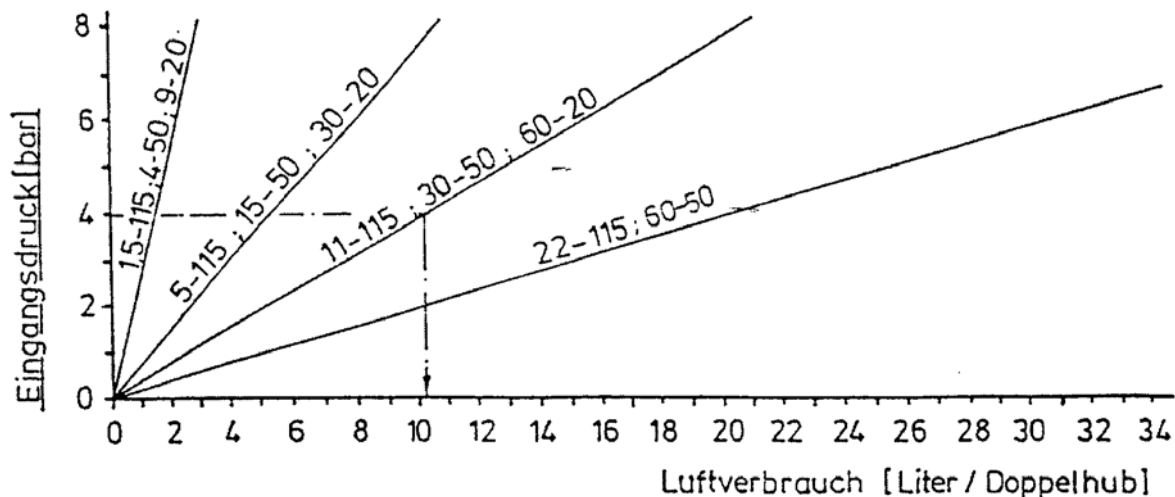

Example  
input air pressure: 4,0bar  
pump type: 30-50  
air consumption/double stroke: 5.45litres

pressure transformation ratio	30:1
delivery volume/double stroke	100ccm
max. recommended double strokes/minute	50
max. air pressure	8bar
max. spray agent pressure in bar	240bar
recommended delivery volume	5,0l/min (50 double strokes/minute)
max. delivery volume	10,0l/min (100 double strokes/minute)

Bezeichnung	HD-Pumpe
Typ	30-50
Artikel	7240-000

## 6 Trouble shooting guide

kind of malfunction	pump does not start or Stops running durin operation	no or insufficient pump sucking	spray pressure to low	uneven operation of pump	pump continues running even though spray gun is closed	pump feeds agent into rinsing chamber	iced control
origin of malfunction (unit)							
drive	clean control and defective parts			clean control and defective parts			pump runs too fast
hydraulic unit		insufficient venting, leaking screwing between hydraulic unit and suction gear		insufficient venting, leaking screwing between hydraulic unit and suction gear			
suction gear		mesh basket obstructed		mesh basket obstructed			
high pressure filter	filter contaminated, check for passage and cleanliness						
high pressure material hose	choked hose, check for passage and cleanliness						
suction/pressure valve		worn or blocked, replace defective parts					
sealing sets		leaking gaskets				upper gasket set leaking	
atomizer nozzle	nozzle bore choked		excessive nozzle bore				excessive nozzle bore
pressure reducing valve	air pressure too low		air pressure too low				
compressed air piping	insufficient air quantity, air pressure too low		insufficient air quantity, air pressure too low				
spray agent		viscosity too high					

## 7 Units of the airless-pump 30-50

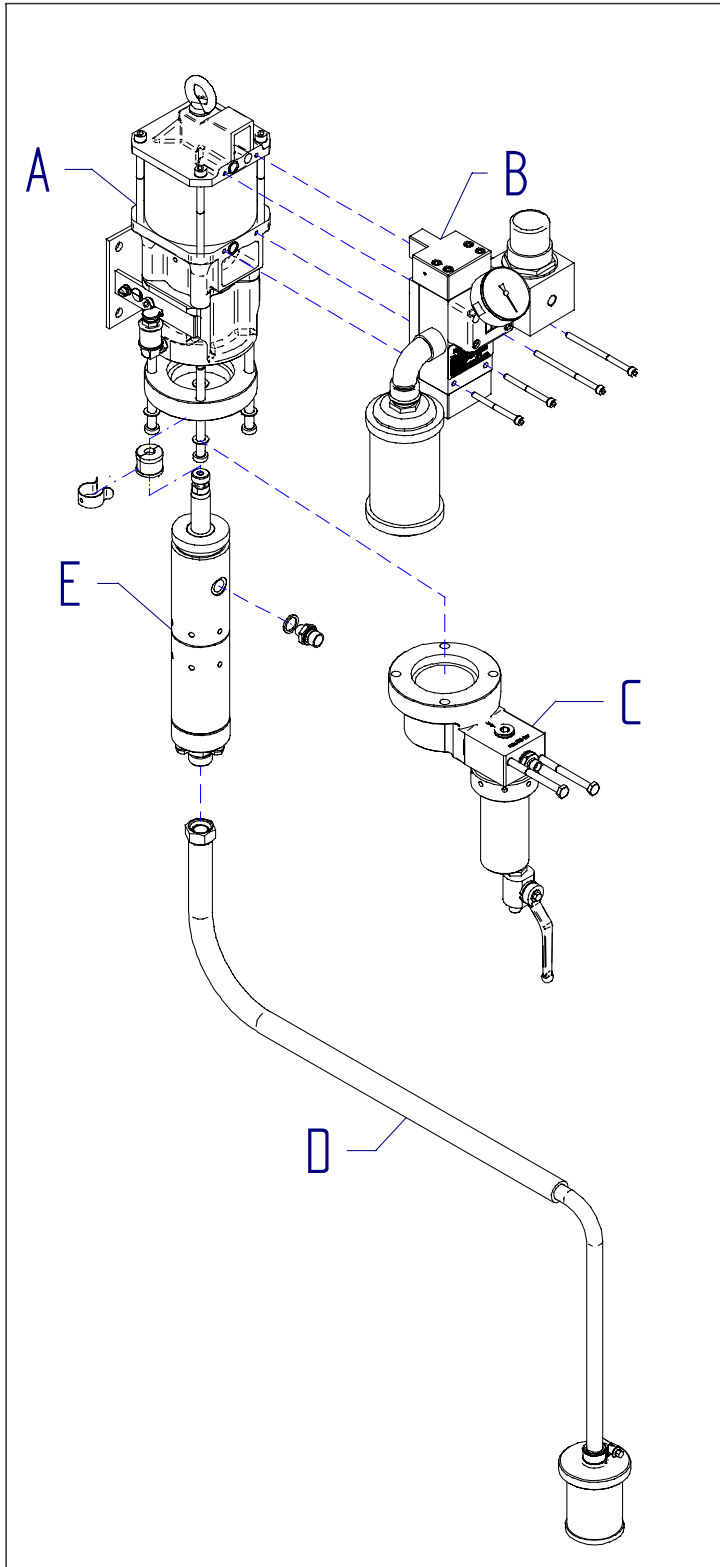

Item	designation	order no
A	motor, compl.	080-0457
B	control unit, compl.	080-3141
C	filter compl.	-
D	suction gear, compl.	-
E	Hydraulic section, compl.	090-0006

## 8 Spare parts drawing motor

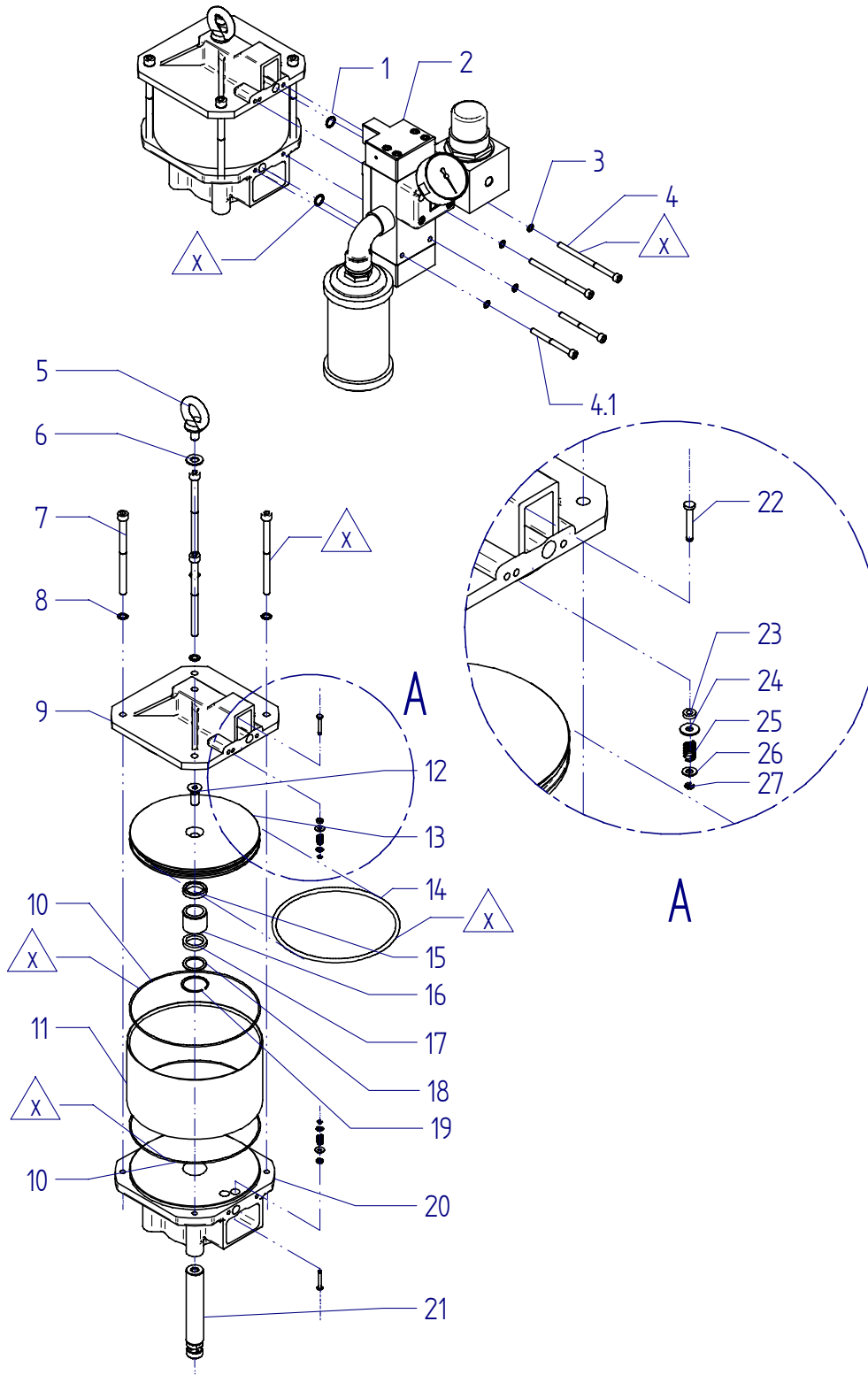

### spare parts list motor 70

Item	Designation	Order-no.
1	o-ring, nbr	010-0241
2	Control section	080-3141
3	Circlip	030-0706
4	Cheese head screw, M6x100	030-0315
4.1	Cheese head screw, M6x70	030-0310
5	Ring bolt	030-0143
6	Washer	030-2867
7	Cheese head screw M8x115	030-0512
8	Circlip	030-0714
9	Upper part motor	040-0026
10	o-ring, nbr	010-0259
11	Cylinder tube	040-0031
12	Screw M10x25	030-0354
13	Piston	040-0032
14	o-ring, nbr 80	010-0258
15	Slotted ring, nbr 90	010-0898
16	Bush	040-0041
17	Slotted ring, nbr 90	010-0898
18	Disk	040-0042
19	Circlip	030-0718
20	Lower part motor	040-0445
21	Piston rod	040-0030
22	Tappet rod	040-0034
23	Slotted ring, nbr 90	010-0247
24	washer	030-2857
25	Pressure spring	020-0076
26	Washer	030-2856
27	Circlip	030-0719

## 9 Spare parts drawing control unit

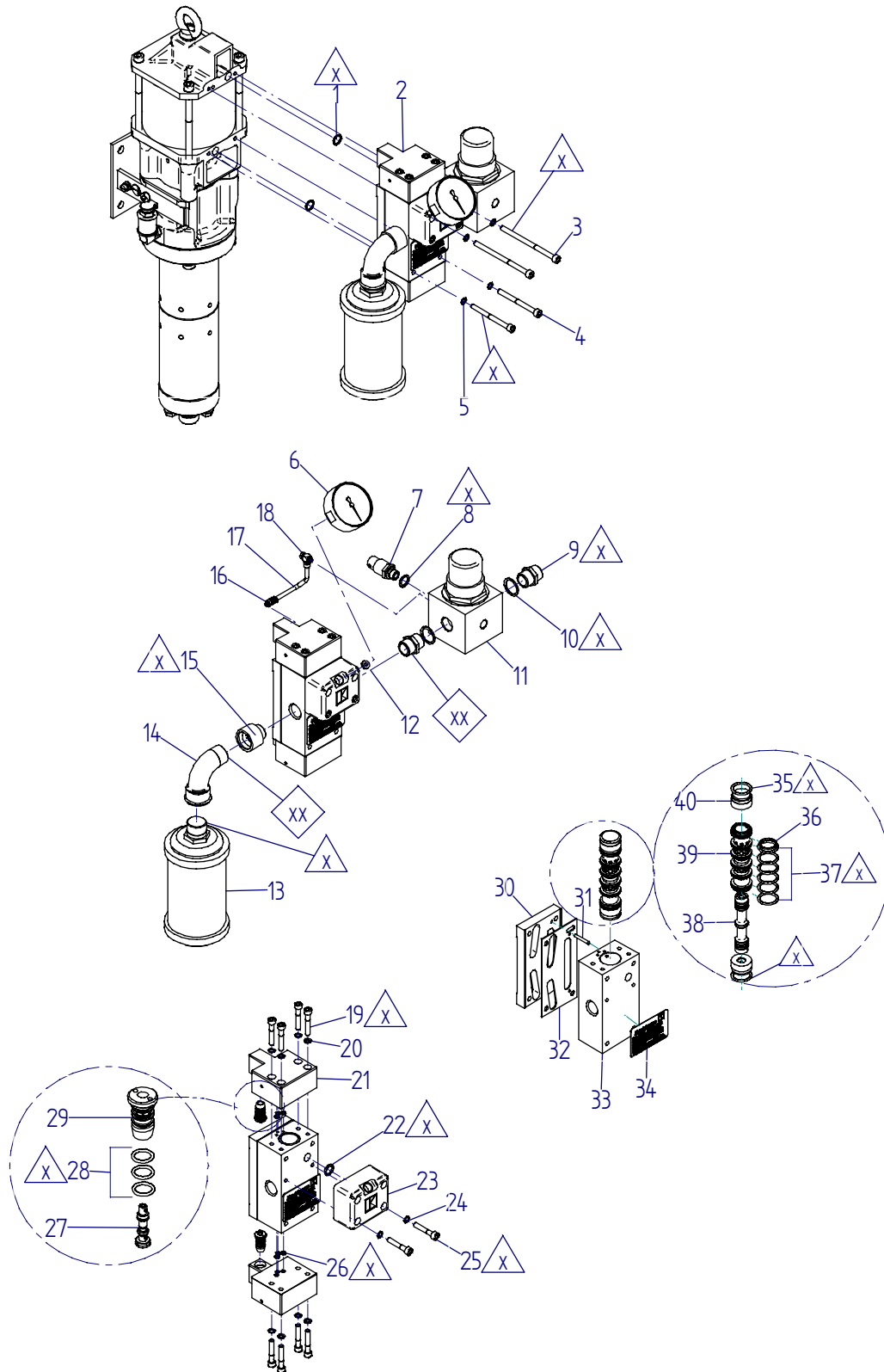

**spare parts list control unit, 8bar pressure**

Pos.	Bezeichnung	Artikel-Nr.
1	o-ring, nbr 70	010-0241
2	Control valve	130-0305
3	Screw, M6x100	030-0315
4	Screw, M6x70	030-0310
5	Circlip	030-0706
6	Pressure gauge, 10bar	030-0720
7	Safety-valve 8,0bar Safety-valve 6,0bar	130-0179 030-2838
8	Gasket, copper	010-0287
9	Double nipple	030-1991
10	Gasket, copper	010-0287
11	Air regulator	030-1313
12	Gasket	010-0251
13	Sound absorber	030-0711
14	Bend	030-2020
15	Extension	030-0708
16	Rapid screw connection	030-2406
17	Hose, max. 8bar	100-0439
18	Swivle screw connection	080-0207
19	Screw, M6x35	030-0294
20	Circlip	030-0706
21	Housing, valve	040-4618
22	o-ring, nbr 70	010-0243
23	Connector	040-0446
24	Circlip	030-0706
25	Screw, M6x35	030-0294
26	o-ring, nbr 70	010-0636
27	Piston	010-0835
28	o-ring, EPDM	010-0188
29	Sleeve	040-3902
30	Air distributor	040-0316
31	Pin	030-2720
32	Gasket	010-0245
33	Housing, steering valve	040-4617
34	Type plate	040-1874
35	o-ring, NBR 70	010-0352
36	o-ring, NBR	010-0741
37	o-ring, NBR 70	010-0352
38	Pusher	030-3852
39	Inner piece	030-4141
40	Spacer piece	040-3329

## 10 Spare parts hydraulic system

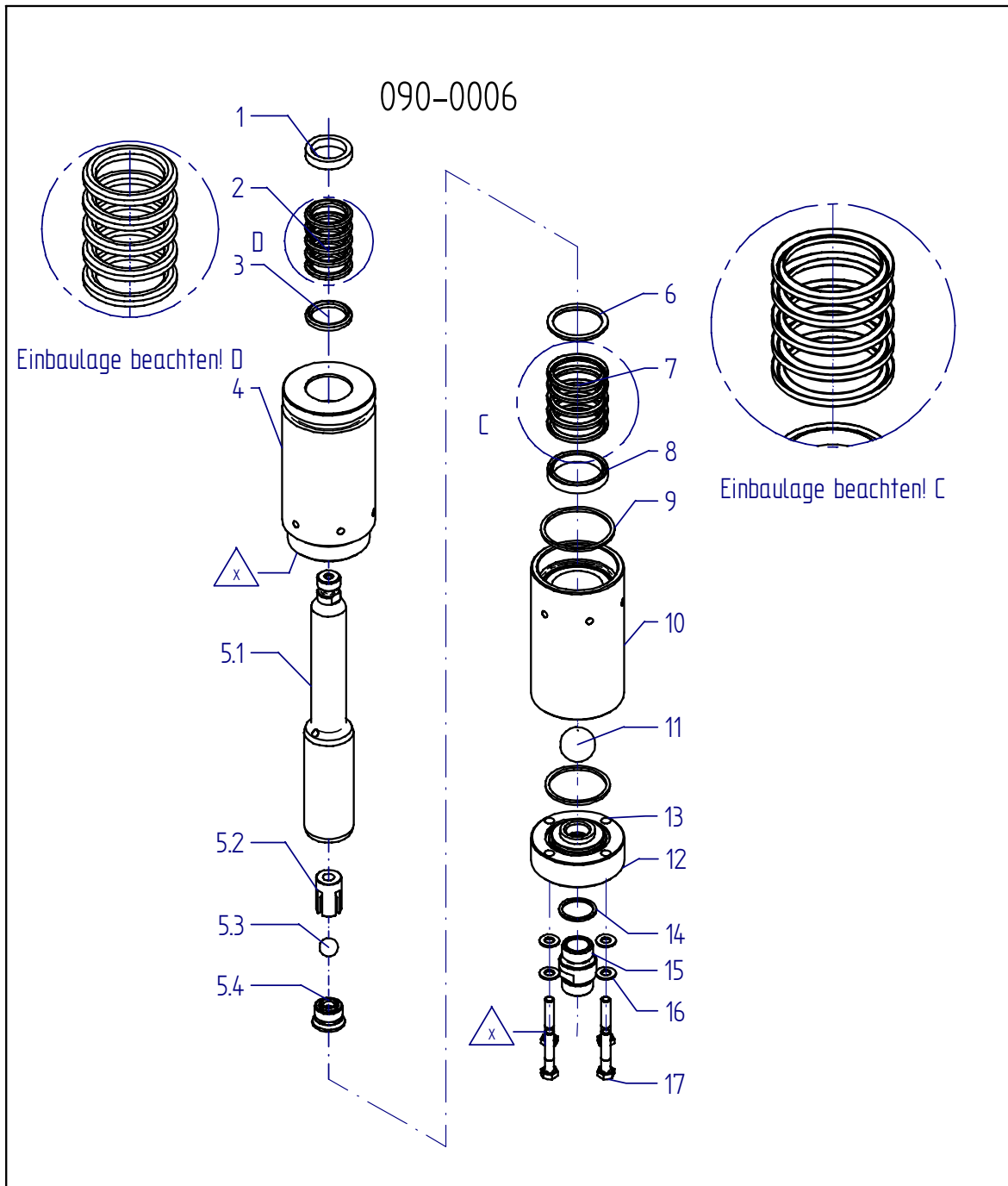

**spare parts list hydraulic system**

Pos.	Bezeichnung	Artikel-Nr.
1	Collar ring	040-3004
2	Slotted ring (5x)	010-0269
3	Ring	040-0592
4	Upper part tube	040-0617
5	Piston, compl.	080-0008
5.1	Piston	040-0620
5.2	Ball guide	040-0599
5.3	Ball	030-2749
5.4	Locking screw	080-0009
6	Ring	040-0593
7	Slotted ring (5x)	010-0270
8	Collar ring	040-3005
9	Gasket	010-0268
10	Lower part tube	040-0616
11	Ball	030-0701
12	closing piece	080-0007
13	Gasket	010-0264
14	Gasket, copper	010-0288
15	Double nipple	040-0025
16	Washer	030-2874
17	Cheese head srew	030-0499

## 11 Filter

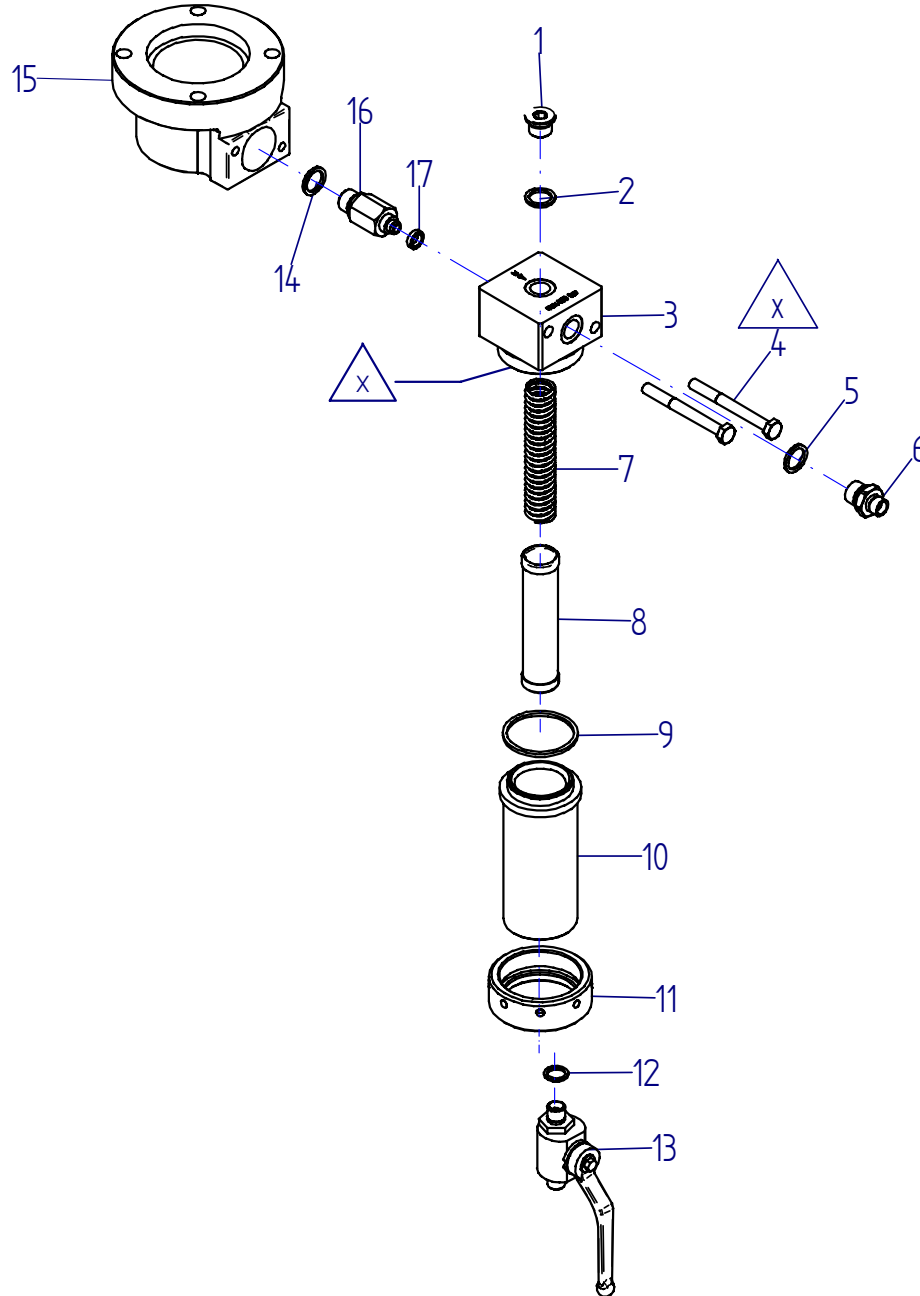

### Spare parts list filter

Pos.	Bezeichnung	Artikel-Nr.
1	Locking screw	030-0526
2	Gasket, copper	010-0260
3	Intermediate piece	040-0462
4	Cheese head screw	030-0515
5	Gasket, copper	010-0260
6	Double nipple	040-0601
7	Support spring	020-0056
8	<i>Filter mesh no. 0, (mesh size 0,02mm)</i>	<i>030-3258</i>
	<i>Filter mesh no. 1, (mesh size 0,06mm)</i>	<i>030-1427</i>
	<i>Filter mesh no. 2, (mesh size 0,075mm)</i>	<i>030-1428</i>
	<i>Filter mesh no. 3, (mesh size 0,08mm)</i>	<i>030-1429</i>
	<i>Filter mesh no. 4, (mesh size 0,09mm)</i>	<i>030-1430</i>
	<i>Filter mesh no. 6, (mesh size 0,20mm)</i>	<i>030-1431</i>
	<i>Filter mesh no. 9, (mesh size 0,25mm)</i>	<i>030-1432</i>
	<i>Filter mesh no. 12, (mesh size 0,30mm)</i>	<i>030-1433</i>
	<i>Filter mesh no. 15 (mesh size 0,40mm)</i>	<i>030-1434</i>
	<i>Filter mesh no. 20, (mesh size 0,51mm)</i>	<i>030-1435</i>
9	Gasket	010-0264
10	Filter housing	040-0463
11	Nut	030-1452
12	Gasket, copper	010-0244
13	Ball valve	030-0960
14	Gasket, copper	010-0260
15	Filter mount	040-0457
16	Connector	040-0603
17	Slotted ring	010-0265

## 12 Suction gear

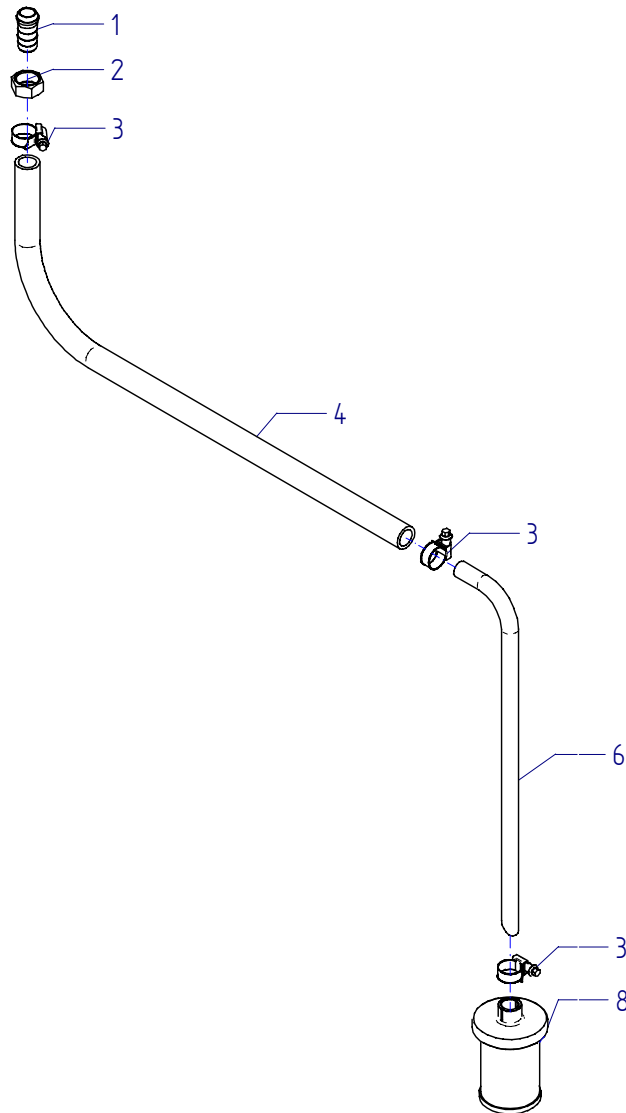

Pos.	Bezeichnung	Artikel-Nr.
1	Hose nozzle	040-1300
2	Union nut	040-1246
3	Hose clip	030-1396
4	Suction hose	110-0005
6	Suction pipe	040-0886
8	Suction pipe	080-0066

**EG-Konformitätserklärung** CE Declaration of Conformity, Déclaration de conformité européenne, Declaración de conformidad CE

gemäß Anhang II A der EG – Maschinenrichtlinie 98/37/EG in acc. with Annex II A of the EC Machine Directive 98/37/EC, Selon la directive européenne 98/37/CEE, annexe II A, relative aux machines, según Anexo II A de la Directiva sobre maquinaria CE 98/37/EG



Krautzberger GmbH  
Stockbornstraße 13  
65343 Eltville am Rhein

**HIERMIT ERKLÄREN WIR, DASS FOLGENDE PRODUKTE** We hereby declare that the following product, garantissons que la version livrée des machines mentionées ci-dessous, Por la presente declaramos que el siguiente producto

**Bezeichnung** Designation, Désignation, Denominación Kolbenpumpen 30-10, 9-20, 30-20, 60-20, 4-50, 15-50, 30-50, 60-50, 1-115, 5-115, 11-115, 22-115

**Geräte-Nummer** Unit no., N° de l'appareil, Núm. aparatos ■ 7110, ■ 7100, ■ 7120, ■ 7140 ■ 7200, ■ 7220, ■ 7240  
■ 7260, ■ 7300, ■ 7320, ■ 7340 ■ 7360

**Funktion** Function, Fonction, Funcionamiento Druckluft betriebene Verdrängerkolbenpumpen zur Druckbeaufschlagung von flüssigen bis hochviskosen Medien Compressed air-driven pump for painting and coating applications, Pompe à commande pneumatique étudiée pour répondre aux besoins de la technologie de pulvérisation, Bomba accionada por aire comprimido para el sector de pintura y recubrimientos

**IN DER GELIEFERTEN AUSFÜHRUNG FOLGENDEN BESTIMMUNGEN ENTSPRICHT** complies with the following provisions in its delivered version:, satisfait aux exigences suivantes :, de la versión suministrada responde a las siguientes disposiciones:.

- **EG-Maschinenrichtlinie 98/37 EG** EC Machine Directive 98/37/EC, Directive européenne 98/37/CEE relative aux machines, Directiva sobre maquinaria CE 98/37/EG

**FOLGENDE HARMONISIERTE EU-NORMEN WURDEN ANGEWENDET:** The following harmonised EU standards were applied:, Les normes d'harmonisation européennes suivantes ont été appliquées :, Se han aplicado las siguientes normas UE armonizadas:

- DIN EN 292 Teil 1 und 2
- DIN EN 809
- DIN EN 12639
- DIN EN 1050

**FOLGENDE NATIONALE NORMEN WURDEN ANGEWENDET** The following national standards were applied:, Les normes nationales suivantes ont été appliquées :, Se han aplicado las siguientes normas nacionales:.

- DIN 24289 Teil 1 und 2
- DIN 24299 Teil 1 und 2

**Datum / Unterschrift** Date / Signature, Date/ signature, Fecha / Firma 24.02.2004

i.A. 

**Angaben zum Unterzeichner** Leiter Konstruktion  
Details of signatory, Fonction, Mención del firmante Head of Design, Directeur de la construction, Director de diseño

M. Stoffels