

Operating instructions and spare parts list

DOK-259-GB.doc

Rev. 1

designation **airless spray appliance**

type **9-20**

Order-No.: 7100-000

- keep for further use -

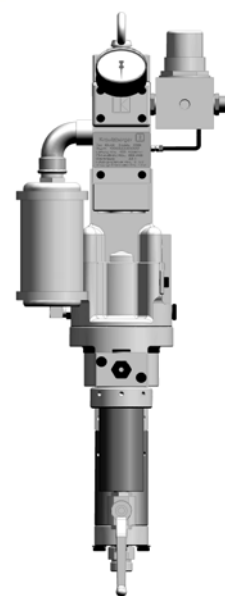

Krautzberger 

1	Method of operation of the positive-displacement pump.....	2
2	Mounting and installation	2
3	Start-up	3
4	Switching off.....	4
5	Maintenance	4
6	Technical data	5
7	Trouble shooting guide	6
8	Units of the airless-pump 9-20.....	7
9	Motor M 70.....	8
10	Spare parts drawing control unit... ..	10
11	Hydraulic system	12
12	Rinsing chamber and pump holder	14

The Airless process

Atomization and agent application are brought about without the use of air, thus the term Airless. The agent is being atomized by squeezing it under an extremely high pressure through the small bore of the material nozzle. In the process the agent is disintegrated into individual particles.

The pressure required for the Krautzberger Airless process may attain up to **480bar** and is generated by compressed air operated positive-displacement piston pumps.

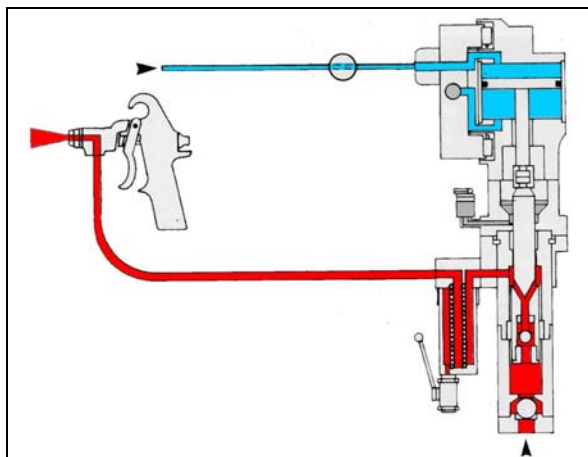

Advantages of the Airless spray

- upgrated spray performances
- instant surface coating due to a full and saturated homogeneous

spray pattern and instant film formation

- reduced spray time
- increased material yield due to minimized spray fogs and low material rebound.
- fatigueless working brought about by a light and handy spray gun design equipped with only on material supply hose
- optimized atomisation even of high viscous materials

1 Method of operation of the positive-displacement pump

By means of an independently controlled air motor which is alternately applying pressure onto the motor piston, the recuperator piston of the pump is moved upwards and downwards.

Air motor and recuperator piston are interconnected via an coupling system.

Whilst moving upwards the suction valve is opened and the agent is sucked into the lower chamber of the hydraulic unit. Simultaneously the pressure valve located in the piston is being closed and the recuperator piston feeds the agent into the hydraulic unit.

The set spray pressure and the adopted nozzle size determine the stroke frequency, the air consumption, and thus the respective spray performance of the positive-displacement pump.

All agent conveying pump components consist of special steel 18/8

2 Mounting and installation

The Airless pump is to be installed in such a way as to render it easily accessible for maintenance and cleaning purposes.

The pump holder is provided with an earthing screw to which the ground wire must be connected in order to ground the static charge generated by the agent flowing within the hose.

Connect the Airless pump only with a heavy duty compressed-air supply net: designed for a maximum compressed air consumption.

PRIOR TO START-UP, CLOSE THE PRESSURE REGULATOR OF THE AIRLESS PUMP BY COUNTER-CLOCKWISE TURNING THE HAND-WHEEL.

The piping supplying compressed air to the Airless-pump should have a nominal width of 9.

Furthermore we recommend to provide the compressed air supply net with an oil- and water separator in order to prevent foreign bodies from penetrating into both air motor and independently operating control system.

If need be a compressed air-oiler with deicing agent maybe installed between airless pump and oil/water separator.

Use only the original suction gear in order to ensure proper pump sucking.

Engage spray gun's safety catch and connect the material supply hose at the outlet of the high-pressure filter.

WHEN IT COMES TO MATERIAL SUPPLY HOSES WITH SAFETY CONDUCTOR IN ORDER TO PREVENT ELECTROSTATIC CHARGES FROM BEING GENERATED.

CAUTION:

With regard to operating the Airless pump we refer to the safety rules edited and published by the applicable employers liability insurance.

3 Start-up

Each time before you start working, check the firm seat of the air and material connections!

Each time before you start working, check the hose lines for wear and damage!

Loose, pressurised hoses may cause accidents due to whiplash-like movement and the discharge of fluids.

- Entirely close pressure regulator at motor
- connect compressed air-hose (max. 8bar)
- in case the pump is provided with a material filter, (strongly recommended by us) a filter mesh matching the nozzle requirements must be used. See table
- Fill rinsing agent into the rinsing chamber, until the sight glass shows a 70% fillin level
- Slowly open pressure regulator until air motor starts working.
- Rinse the Airless pump by means of the rinsing agent in order to get the preservatives out of the pump
- put the suction hose into the spray agent
- open spray gun in order to evacuate the air still contained in the system
- When the spray agent starts to emerging from the spray gun, close spray gun and set the required working pressure at the pressure regulator (max 8bar)

CAUTION!

PAY ATTENTION TO THE PRESSURE TRANSFORMATION RATIO!

Under no-load conditions the Airless-pump must only be operated for a short time and at a slow running level.

Otherwise motor, suction valve, piston valve and the pump sealing may be damaged.

CAUTION!

The spray jet emerging from the spray gun is dangerous. For this reason aim the spray gun only downwards.

4 Switching off

Switching-off

- Entirely close pressure regulator at motor
- disconnect spray gun and render the system pressureless.
- remove and clean the spray nozzle
- remove suction hose out of the spray agent and put it in a thinner

Observe the safety instructions of the detergent manufacturer. Detergents can be harmful to your health and may be highly flammable!

- slowly open pressure regulator whilst the spray gun is being opened, until the air motor starts working

- rinse spray gun and pump by means of a thinner. In the process make sure that the motor runs at a slow level only
- for rough cleaning of the filter during rinsing, shortly open the cock at filter

5 Maintenance

Daily check rinsing agent level during operation. Sight glass must show a 70% filling level.

In case the rinsing agent is contaminated by the spray agent, replace the rinsing agent. If, after a short time only, the rinsing agent should again be contaminated or should the rinsing agent level displayed by the sight glass increase, we recommend to replace the gaskets in the hydraulic system.

By replacing these gasket sets, the recuperator piston prevented from being worn out prematurely.

We recommend to open the material filter at fixed intervals in order to clean the filter housing, mesh inclusive.

CAUTION!

Prior to opening material filter refer to instructions

6 Technical data

Air consumption

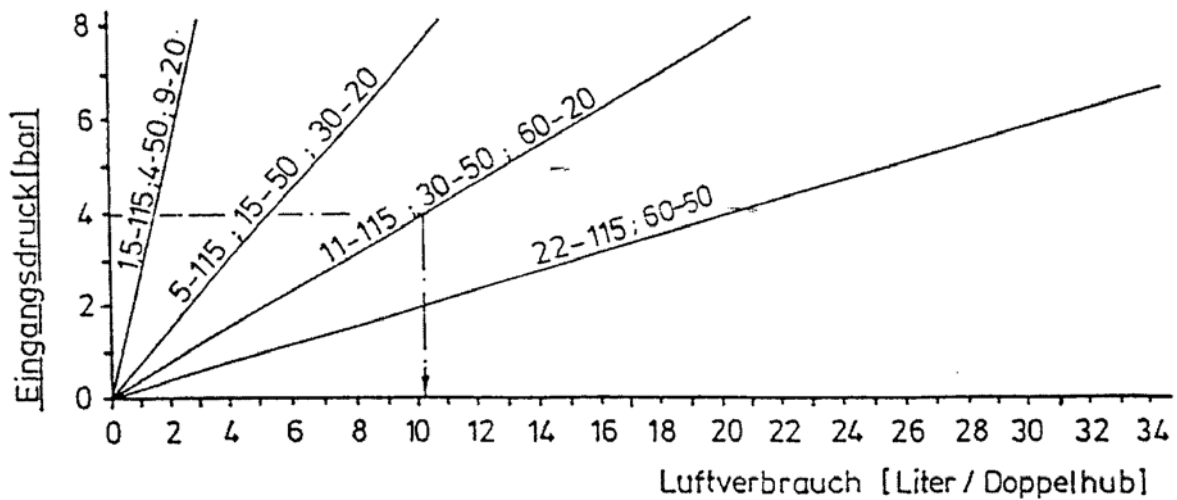

Example

input air pressure: 4,0bar
 pump type: 4-50
 air consumption/double stroke: 5.45litres

pressure transformation ratio	9:1
delivery volume/double stroke	40ccm
max. recommended double strokes/minute	50
max. air pressure	8bar
max. spray agent pressure in bar	72bar
recommended delivery volume	2,0l/min (50 double strokes/minute)
max. delivery volume	4,0l/min (100 double strokes/minute)

7 Trouble shooting guide

kind of malfunction / origin of malfunction (unit)	pump does not start or Stops running durin operation	no or insufficient pump sucking	spray pressure to low	uneven operation of pump	pump continues running even though spray gun is closed	pump feeds agent into rinsing chamber	iced control
drive	clean control and defective parts			clean control and defective parts			pump runs too fast
hydraulic unit		insufficient venting, leaking screwing between hydraulic unit and suction gear		insufficient venting, leaking screwing between hydraulic unit and suction gear			
suction gear		mesh basket obstructed		mesh basket obstructed			
high pressure filter	filter contaminated, check for passage and cleanliness						
high pressure material hose	choked hose, check for passage and cleanliness						
suction/pressure valve		worn or blocked, replace defective parts					
sealing sets		leaking gaskets				upper gasket set leaking	
atomizer nozzle	nozzle bore choked		excessive nozzle bore				excessive nozzle bore
pressure reducing valve	air pressure too low		air pressure too low				
compressed air piping	insufficient air quantity, air pressure too low		insufficient air quantity, air pressure too low				
spray agent		viscosity too high					

8 Units of the airless-pump 9-20

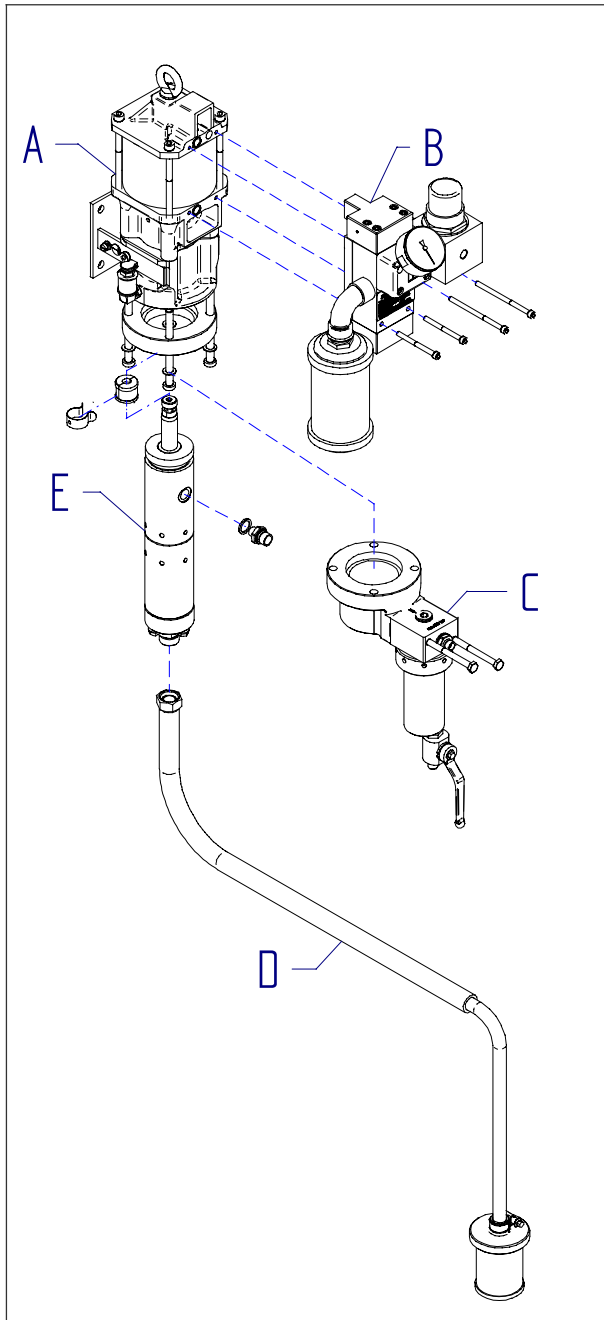

Item	designation	Order No.
A	motor, compl.	7100-080-0414
B	control unit, compl.	7100-080-3141
E	Hydraulic section, compl.	7100-090-0007
C	filter compl.	7100-080-0013
D	suction gear, compl.	7100-080-0298

9 Motor M 70

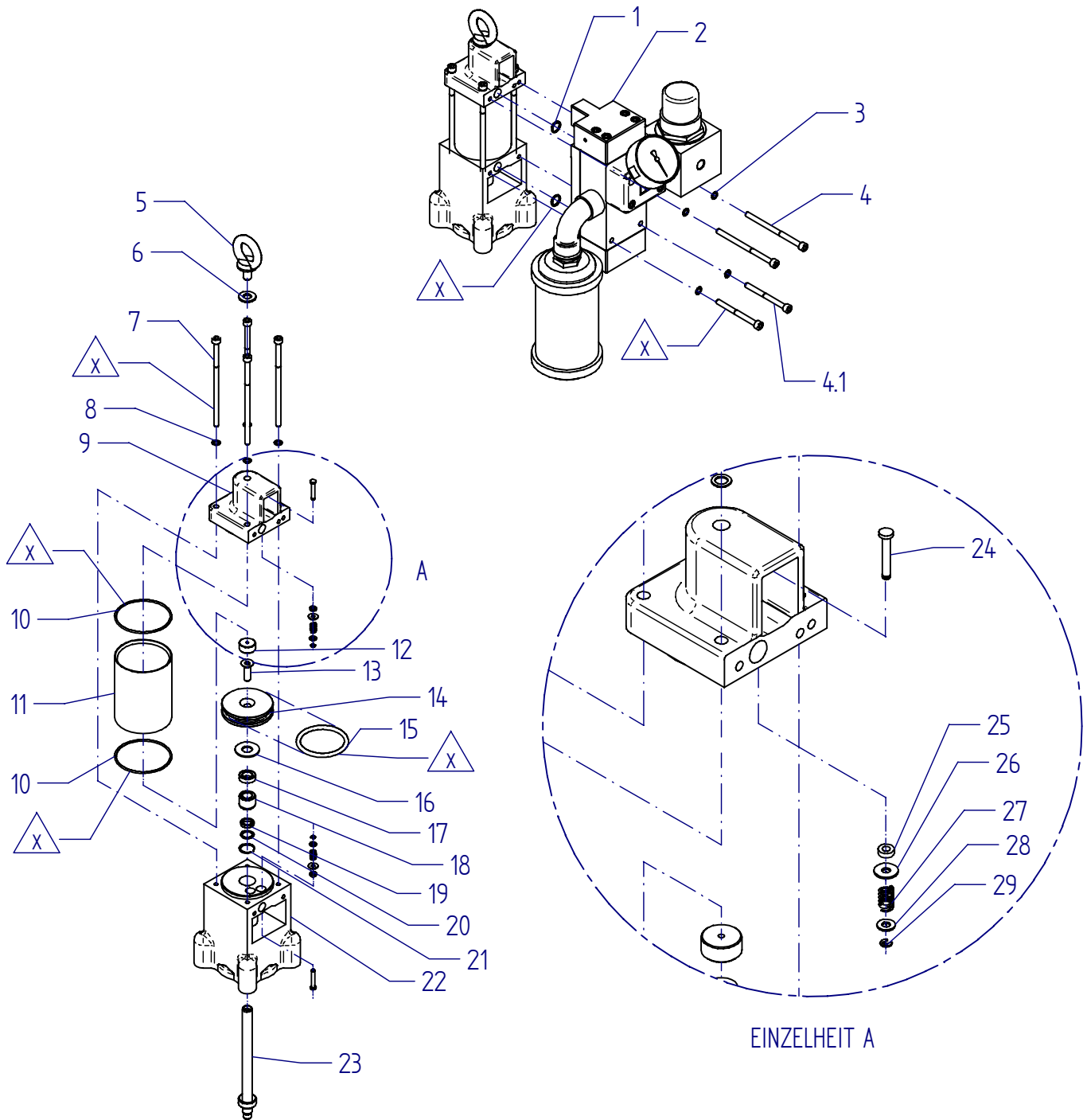

Motor M-70

Item	Designation	Order-no
1	O-Ring, NBR 70	010-0241
2	Control section, cpl.	080-3141
3	Circlip	030-0706
4	Screw M6x95	030-0533
4.1	Schrew M6x68	040-4896
5	Ring bolt, M10x17	030-0143
6	Washer	030-2867
7	Screw M6x125	030-0509
8	Circlip	030-0706
9	Upper part motor	040-0426
10	O-Ring, NBR 70	010-0250
11	Cylinder tube	040-0427
12	stopper (n/a 10-03)	040-0431
13	Countersunk screw M8x25	030-0510
14	Piston	040-0428
15	O-Ring, NBR 80	010-0249
16	stopper (n/a 10-03)	040-0432
17	Slotted ring, NBR 90	010-0253
18	Bushing 20x15	040-1301
19	Slotted ring, PTFE	010-0190
20	Disk, motor	040-0436
21	Circlip	030-2804
22	Lower part, motor	040-0425
23	Piston rod	040-0429
24	Tappet rod	040-0034
25	Slotted ring, NBR 90	010-0247
26	Washer	030-2857
27	Spring	020-0076
28	Washer	030-2856
29	Circlip	030-0719

10 Spare parts drawing control unit

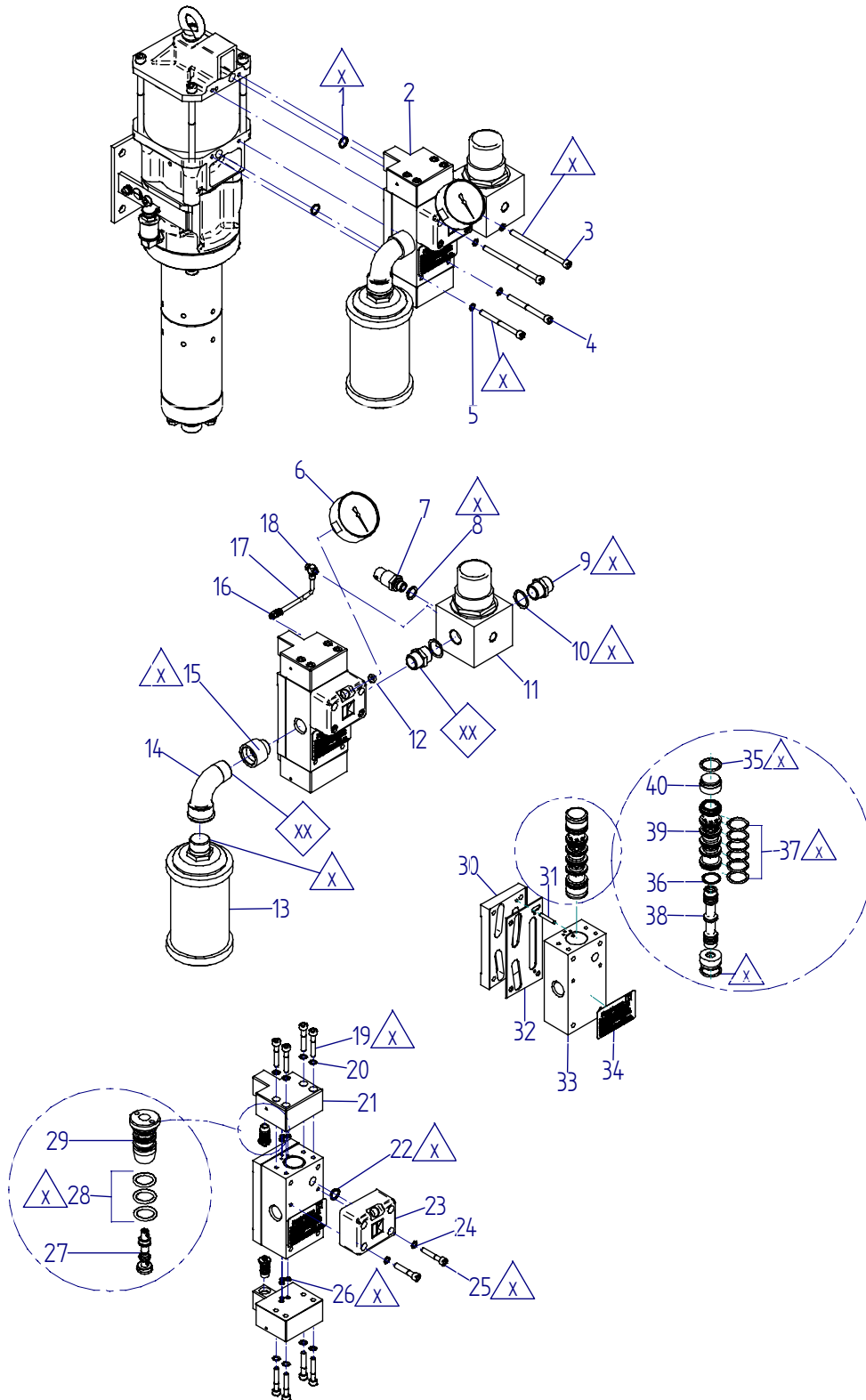

spare parts list control unit

Item	Designation	Order-no	Number of items
1	O-Ring NBR 70	010-0241	2
2	Controll valve complete	130-0305	1
3	Screw M6x95 (M-70) Screw, M6x100	030-0533 030-0315	2
4	Screw M6x68 (M-70) Screw, M6x70	040-4896 030-0310	2
5	Safety disk , VA 1.4122	030-0706	4
6	Pressure gauge, 10bar	030-0720	1
7	Mini-safety valve 8,0bar Mini-safety valve 6,0bar	130-0179 030-2838	1 1
8	Gasket, Copper	010-0287	1
9	Double nipple, brass, 2xG3/4"	030-1991	2
10	Gasket, copper	010-0287	2
11	Pressure regulator	030-1313	1
12	Gasket	010-0251	1
13	Sound absorber	030-0711	1
14	Bend		1
15	Extension IG 3/4"-AG1/2"	030-0708	1
16	Rapid srew connection, Messing, PH 3-5	030-2406	1
17	Hose, max. 8bar, l=82mm	100-0439	1
18	swivle screw connection, brass, PH 3-5	080-0207	1
19	Screw, M6x35	030-0294	8
20	Safety disk	030-0706	8
21	Housing	040-4618	2
22	O-Ring, NBR 70	010-0243	1
23	Connector	040-0446	1
24	Safety bolt, VA 1.4122	030-0706	2
25	Screw, M6x35	030-0294	2
26	O-Ring, NBR 70	010-0636	6
27	Control piston	010-0835	2
28	O-Ring, EPDM	010-0188	6
29	Take-up sleeve	040-3902	2
30	Air distributor	040-0316	1
31	Grip sleeve	030-2720	1
32	Gasket	010-0245	1
33	Housing	040-4617	1
34	Type label	040-1874	1
35	O-Ring, NBR 70	010-0352	2
36	O-Ring, NBR	010-0741	1
37	O-Ring, NBR 70	010-0352	6
38	Slide valve, Alu	030-3852	1
39	Inner part, brass	030-4141	1
40	Spacer	040-3329	2

11 Hydraulic system

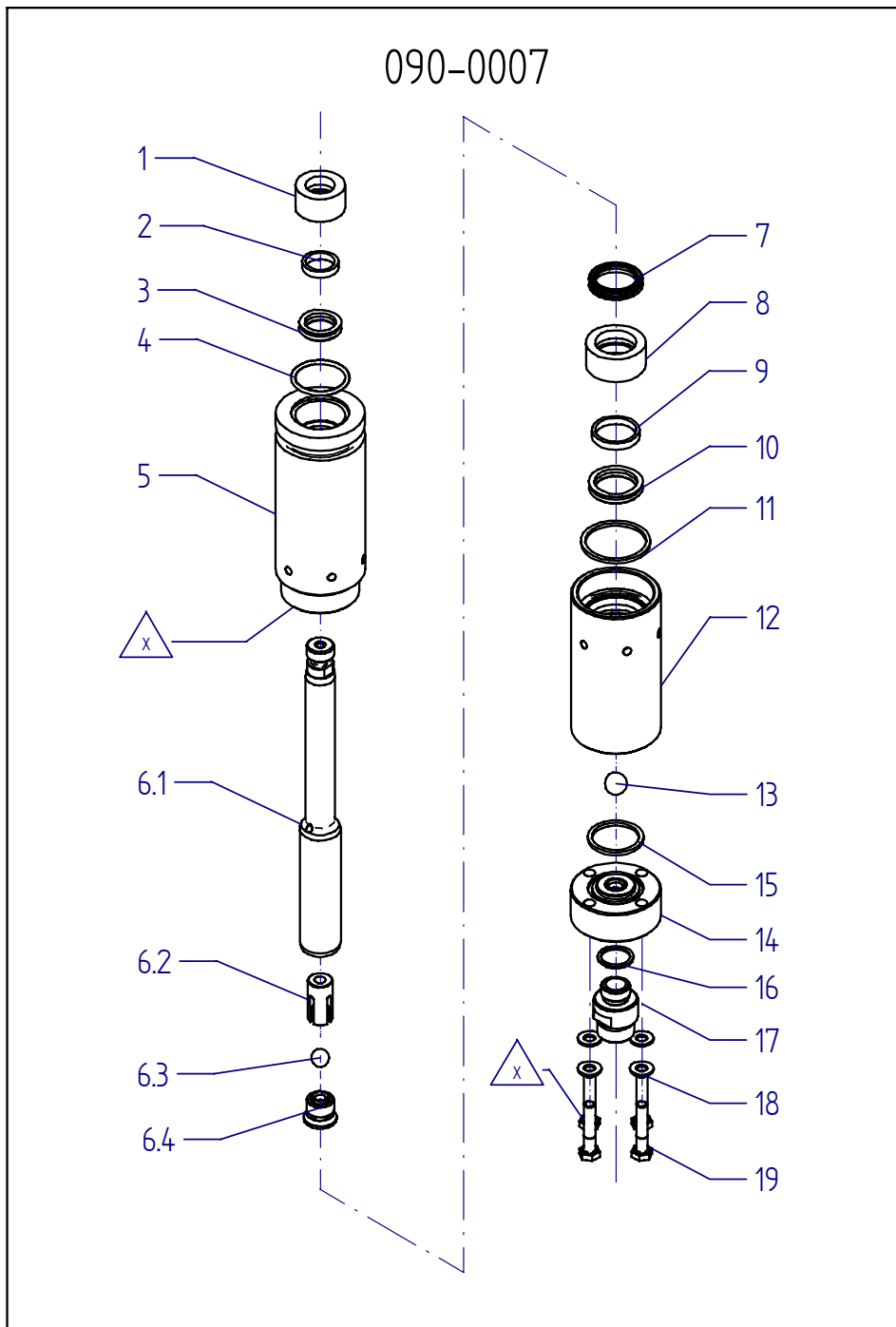

Hydraulic system 090-0007

Item	Designation	Order-no.
1	Adapter	040-0613
2	Guide band, 73mm lang	030-1882
3	Slotted ring	010-0275
4	O-Ring	010-0279
5	Upper part tube	040-0609
6	Piston, cpl.	080-0004
6.1	Piston	040-0611
6.2	Valve guide	040-0598
6.3	Ball	030-2746
6.4	Fastener, cpl.	080-0005
7	Slotted ring	010-0277
8	Adapter	040-0614
9	Guide band, 99,5mm lang	030-1883
10	Slotted ring	010-0277
11	Gasket UHMW-PE	010-0262
12	Lower part tube	040-0610
13	Ball	030-2749
14	Pump fastener, cpl.	080-0003
15	Gasket UHMW-PE	010-0263
16	Gasket, copper	010-0287
17	Reducing nipple G3/4"AG - G1/2"AG	040-0600
18	Washer, M8	030-2874
19	Hexagonal nut M8x40	030-0499

12 Rinsing chamber and pump holder

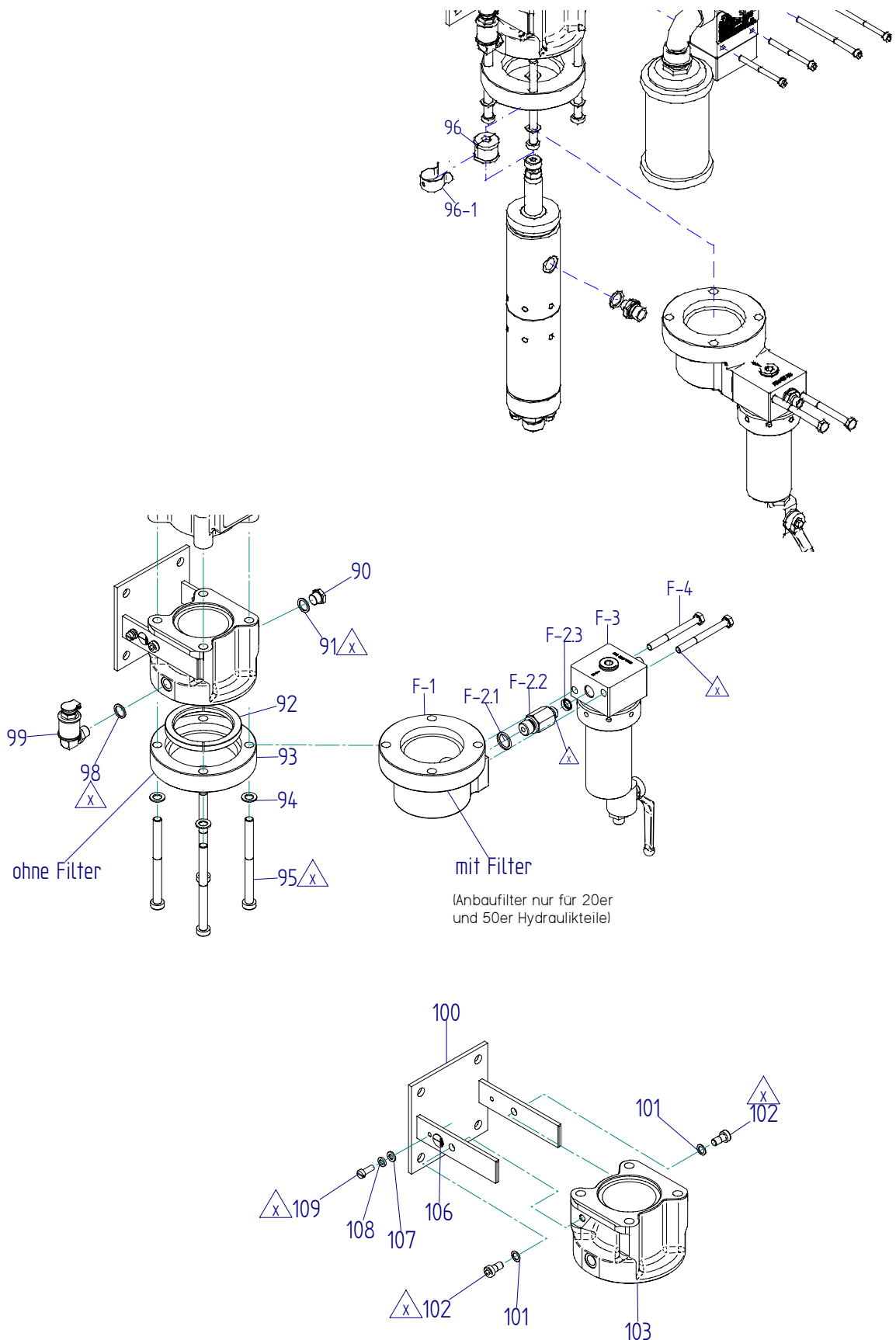

Item	Designation	Order-No.	Number of items
90	Screw, MS	030-0516	1
91	Gasket, Cu	010-0244	2
92	ring X/20 ring X/50	040-0460 040-0461	
93	clipring X/20 clipring X/50	040-0458 040-0459	
94	disk disk (x-20, x-50, x-115)	030-2869 030-0704	4
95	Hexagonal screw M10x120 Hexagonal screw M10x160 (only 115 hydraulic-systems)	030-0514 030-2963	4
96	Coupling (xx-20, 4-50, 15-50, 30-50) Coupling (60-50 + 22-115)	040-0062 080-0585	1
96-1	Spring	020-0150	1
98	Gasket	010-0244	1
99	Gauge	030-1879	1
100	Pump holder	080-0006	1
101	Safety disk	030-0714	2
102	Hexagonal nut M8x16	030-0524	2
103	Rinsing chamber X/20 Rinsing chamber X/50 Rinsing chamber X/115	040-0060 040-0455 040-0605	1
106	label	040-1878	1
107	Disk, brass	030-2863	1
108	Serrated washer	030-2894	1
109	Hexagonal nut M6x16	030-0274	1

Version build-on filter		
Item	Designation	Order-No.
F-1	Filter bracket X/20 Filter bracket X/50	040-0456 040-0457
F-2	Filter connection cpl. X/20 Filter connection cpl. X/50	080-0034 080-0035
F-2.1	Gasket copper	010-0260
F-2.2	Filter connection X/20 Filter connection X/50	040-0602 040-0603
F-2.3	Slotted ring	010-0265
F-3	Filter cpl.	080-0013
F-4	Hexagonal nut M8x80 washer	030-0515 030-0714

EG-Konformitätserklärung CE Declaration of Conformity, Déclaration de conformité européenne, Declaración de conformidad CE

gemäß Anhang II A der EG – Maschinenrichtlinie 98/37/EG in acc. with Annex II A of the EC Machine Directive 98/37/EC, Selon la directive européenne 98/37/CEE, annexe II A, relative aux machines, según Anexo II A de la Directiva sobre maquinaria CE 98/37/EG



Krautzberger GmbH
Stockbornstraße 13
65343 Eltville am Rhein

HIERMIT ERKLÄREN WIR, DASS FOLGENDE PRODUKTE We hereby declare that the following product, garantissons que la version livrée des machines mentionnées ci-dessous, Por la presente declaramos que el siguiente producto

Bezeichnung Designation, Désignation, Denominación	Kolbenpumpen 30-10, 9-20, 30-20, 60-20, 4-50, 15-50, 30-50, 60-50, 1-115, 5-115, 11-115, 22-115
Geräte-Nummer Unit no., N° de l'appareil, Núm. aparatos	■ 7110, ■ 7100, ■ 7120, ■ 7140 ■ 7200, ■ 7220, ■ 7240 ■ 7260, ■ 7300, ■ 7320, ■ 7340 ■ 7360

Funktion Function, Fonction, Funcionamiento	Druckluft betriebene Verdrängerkolbenpumpen zur Druckbeaufschlagung von flüssigen bis hochviskosen Medien Compressed air-driven pump for painting and coating applications, Pompe à commande pneumatique étudiée pour répondre aux besoins de la technologie de pulvérisation, Bomba accionada por aire comprimido para el sector de pintura y recubrimientos
--	---

IN DER GELIEFERTEN AUSFÜHRUNG FOLGENDEN BESTIMMUNGEN ENTSPRICHT complies with the following provisions in its delivered version:, satisfait aux exigences suivantes :, de la versión suministrada responde a las siguientes disposiciones:.

- **EG-Maschinenrichtlinie 98/37 EG** EC Machine Directive 98/37/EC, Directive européenne 98/37/CEE relative aux machines, Directiva sobre maquinaria CE 98/37/EG

FOLGENDE HARMONISIERTE EU-NORMEN WURDEN ANGEWENDET: The following harmonised EU standards were applied:, Les normes d'harmonisation européennes suivantes ont été appliquées :, Se han aplicado las siguientes normas UE armonizadas:

- | | |
|---------------------------------|----------------|
| ▪ DIN EN ISO 12100 Teil 1 und 2 | ▪ DIN EN 12639 |
| ▪ DIN EN 809 | ▪ DIN EN 1050 |

FOLGENDE NATIONALE NORMEN WURDEN ANGEWENDET The following national standards were applied:, Les normes nationales suivantes ont été appliquées :, Se han aplicado las siguientes normas nacionales:.

- | | |
|--------------------------|--------------------------|
| ▪ DIN 24289 Teil 1 und 2 | ▪ DIN 24299 Teil 1 und 2 |
|--------------------------|--------------------------|

Datum / Unterschrift Date / Signature, Date/ signature, Fecha / Firma 18.04.2005

i.A. 

Angaben zum Unterzeichner Leiter Konstruktion
Details of signatory, Fonction, Mención del firmante Head of Design, Directeur de la construction, Director de diseño

M. Stoffels