

Operating instructions

DOK-172-GB Rev. 2

Automatic spray gun

Type **DUO-A-2**
nozzle system "slot air"
nozzle system „horn air“

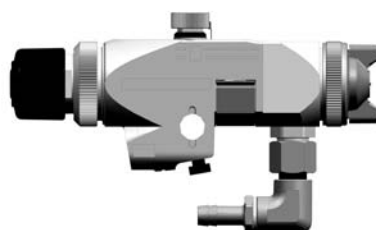

Order-No.: 3220
- keep for further use-

CE

100
100 JAHRE
KRAUTZBERGER

EG-Konformitätserklärung

CE Declaration of Conformity, Déclaration de conformité européenne, Declaración de conformidad CE
gemäß Anhang II A der EG – Maschinenrichtlinie 98/37/EG

in acc. with Annex II A of the EC Machine Directive 98/37/EC, Selon la directive européenne 98/37/CEE, annexe II A, relative aux machines, según Anexo II A de la Directiva sobre maquinaria CE 98/37/EG

Krautzberger 

Krautzberger GmbH
Stockbornstraße 13
65343 Eltville am Rhein

Hiermit erklären wir, dass folgendes Produkt

We hereby declare that the following product, garantissons que la version livrée des machines mentionnées ci-dessous, Por la presente declaramos que el siguiente producto

Bezeichnung

Designation, Désignation, Denominación

Automatic spray gun ■ DUO A-2**Geräte-Nr.**

Unit no., N° de l'appareil, Núm. aparatos

▪ **3220****Funktion**

Function, Fonction, Funcionamiento

Automatische Beschichtung von Oberflächen

In der gelieferten Ausführung folgenden Bestimmungen entspricht:

complies with the following provisions in its delivered version:, satisfait aux exigences suivantes :, de la versión suministrada responde a las siguientes disposiciones:

EG – Maschinenrichtlinie 98/37/EG,

EC Machine Directive 98/37/EC, Directive européenne 98/37/CEE relative aux machines, Directiva sobre maquinaria CE 98/37/EG

Folgende harmonisierte EU-Normen wurden angewendet:

The following harmonised EU standards were applied:, Les normes d'harmonisation européennes suivantes ont été appliquées :, Se han aplicado las siguientes normas UE armonizadas:

DIN EN 292 Teil 1 und 2

DIN EN 10500

DIN EN 1953

Folgende nationale Normen wurden angewendet:

The following national standards were applied:, Les normes nationales suivantes ont été appliquées :, Se han aplicado las siguientes normas nacionales:

Datum / Unterschrift

Date / Signature, Date/ signature, Fecha / Firma

14.11.00, i.A.

**Angaben zum Unterzeichner**

Details of signatory, Fonction, Mención del firmante

Leiter Konstruktion

Head of Design, Directeur de la construction, Director de diseño

M.Stoffels

CONTEND

USE FOR INTENDED PURPOSE	3
MODE OF OPERATION	3
GENERAL SAFETY NOTES	3
SAFETY NOTES WHEN USING HAZARDOUS SUBSTANCES	4
CONNECTIONS	5
START-UP	5
SPRAY PROFILE ADJUSTMENT	6
OPERATIONAL INTERRUPTIONS, CLEANING	6
MAINTENANCE	6
SPARE PARTS DRAWING	8
SPARE PARTS LIST	9

Use for intended purpose

Automatic spray guns are designed for:

- automatic coating/marketing of surfaces
- dosing of liquids
- application of bonding or identification points

Typical coating materials include lacquers, paints, adhesives, glaze coatings, enamel, parting agents etc.

Automatic spray guns must be firmly attached to a suitable supporting device and may not be held in the hand during coating operations.

Due to their compact design, the automatic spray guns are particularly suitable for applications where limited space is available – e.g. spraying robots, production lines or conveyor belts.

Mode of operation

The coating material is fed to the automatic spray gun under pressure. This pressure is typically generated by piston-pumps.

The automatic spray guns are driven using compressed air.

i *Features like electrically driven solenoid valves can be used for precision control of the automatic spray guns – achieving switching times of around 60ms.*

The coating material is atomised using compressed air.

The scope and shape of the jet and the spray volume of the coating material can be adjusted by:

- choosing between various air and material nozzles
- changing the atomiser air pressure
- Changing the coating material pressure
- Adjusting the needle stroke on the regulator of the automatic spray gun

The automatic spray gun is made of the following materials:

- Head section: stainless steel
- Control section, main element: aluminium anodised/hard-coated
- Needle and nozzle: stainless steel
- Gaskets: brass and plastic

General safety notes

PERSONNEL MAY ONLY WORK WITH SPRAY GUNS IF THEY HAVE BEEN TRAINED AND INSTRUCTED IN THE FOLLOWING POINTS:

- POTENTIAL HAZARDS WHEN USING SPRAY GUNS
- SAFETY REGULATIONS
- CONDUCT IN THE EVENT OF ACCIDENT AND MALFUNCTION
- CONTENTS OF THE OPERATING INSTRUCTIONS

 SPRAY GUNS MAY ONLY BE OPERATED IN LINE WITH THE OPERATING PARAMETERS (PRESSURES ETC.) SPECIFIED UNDER "TECHNICAL DATA"!

 THE OPERATOR MUST CHECK THE COMPATIBILITY OF THE GUN MATERIALS WITH THE COATING SUBSTANCE TO BE USED. TO ENSURE COMPATIBILITY, REFER TO THE SAFETY DATA SHEET SUPPLIED BY THE MANUFACTURER OF THE COATING SUBSTANCE!

⚠ ALL WORK CONNECTED WITH INSTALLATION AND MAINTENANCE MUST BE PERFORMED ON A PRESSURELESS GUN BY SUITABLY QUALIFIED PERSONNEL. ALWAYS USE ORIGINAL PARTS WHEN REPLACING WORN OR DAMAGED PARTS!

⚠ EACH TIME BEFORE YOU START WORKING, CHECK THE MATERIAL AND COMPRESSED AIR CONNECTIONS FOR FIRM SEAT AND DAMAGE! LOOSE, PRESSURISED HOSES MAY CAUSE ACCIDENTS DUE TO WHIPLASH-LIKE MOVEMENT AND THE DISCHARGE OF FLUIDS!

⚠ NEVER POINT COMPRESSED AIR AT PEOPLE OR ANIMALS!

⚠ HIGHLY ABRASIVE, CHEMICALLY AGGRESSIVE, EXTREMELY HOT OR EXTREMELY COLD MATERIALS MAY ONLY BE USED IN CONSULTATION WITH KRAUTZBERGER GMBH!

⚠ DEPENDING ON THE NOZZLE, WORKING WITH SPRAY GUNS CAN CREATE NOISE LEVELS THAT MAY DAMAGE HEARING! ALWAYS WEAR EAR MUFFS WHEN WORKING!

⚠ MIXING OF DIFFERENT COATING SUBSTANCES CAN CREATE SUBSTANCES WITH INCREASED HAZARD POTENTIAL. ADHERE TO THE INSTRUCTIONS OF THE MANUFACTURER!

Safety notes when using hazardous substances

⚠ ALWAYS COMPLY WITH THE STIPULATIONS IN THE SAFETY DATA SHEET OF THE MANUFACTURER OF THE COATING SUBSTANCE. IN PARTICULAR, ADHERE TO INSTRUCTIONS RELATING TO:

- THE WEARING OF PERSONAL PROTECTIVE EQUIPMENT.
- THE AVOIDANCE OF EXPLOSIVE OR HARMFUL ENVIRONMENTS.

⚠ ROOMS IN WHICH HAZARDOUS SUBSTANCES ARE STORED OR PROCESSED MUST HAVE ADEQUATE VENTILATION. IT MAY BE NECESSARY TO INSTALL A TECHNICAL VENTILATION SYSTEM. IF THE VENTILATION SYSTEM FAILS, WORK MUST BE STOPPED IMMEDIATELY!

⚠ DO NOT STORE ANY FLAMMABLE SUBSTANCES, EMPTY COATING SUBSTANCE CONTAINERS OR OTHER MATERIALS THAT HAVE BEEN IN CONTACT WITH THE COATING SUBSTANCE (PAPER, CLOTHS ETC.) WITHIN OR IN THE WORKING ZONE.

⚠ IN THE WORKING ZONE, AVOID OPEN FLAMES AND RED-HOT COMPONENTS AS WELL AS EQUIPMENT, TOOLS AND PARTS THAT CAN CREATE IGNITABLE SPARKS.

⚠ HANG UP "NO SMOKING" SIGNS IN A 5 METRE RADIUS OF THE WORKING ZONE. MAKE FIRE EXTINGUISHERS AVAILABLE IF THESE ARE NOT ALREADY IN PLACE!

⚠ COMPLY WITH ALL NATIONAL AND REGIONAL WATER PROTECTION REGULATIONS.
COMPLY WITH ALL NATIONAL AND REGIONAL WASTE DISPOSAL REGULATIONS.

⚠ FRICTION CHARGING DUE TO FLOWING COATING SUBSTANCES AND/OR COMPRESSED AIR CAN LEAD TO ELECTRIC SHOCKS DUE TO ELECTROSTATIC DISCHARGE!
THE SPRAY GUN MUST THEREFORE BE EARTHED!
WHEN THE GUN IS USED IN POTENTIALLY EXPLOSIVE AREAS, THE AIR AND COATING MATERIAL LINES MUST -BE ELECTRICALLY CONDUCTIVE (<1 MEGAOHM) AND MUST BE EARTHED.

“DUO”-Installation-plan

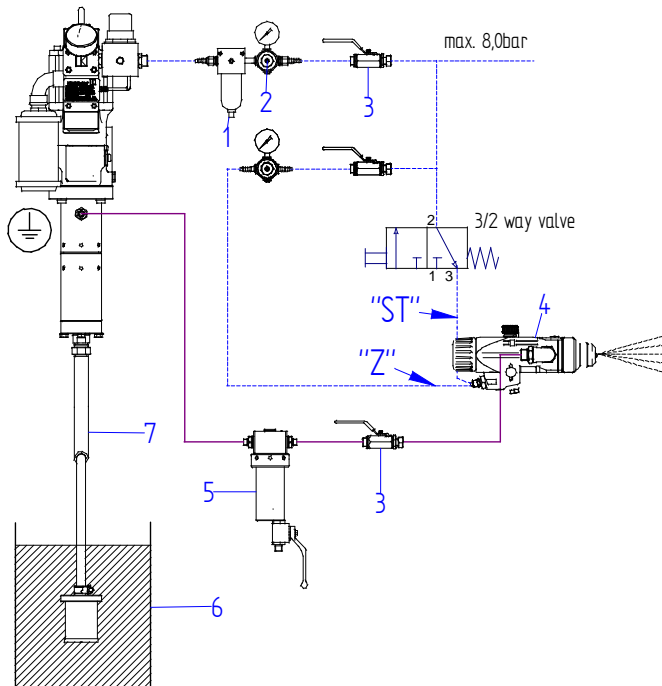

1	Oil- /water seperator
2	Pressure regulator (compressed air)
3	Ball valve
4	Spray gun
5	Filter
6	container

Connections

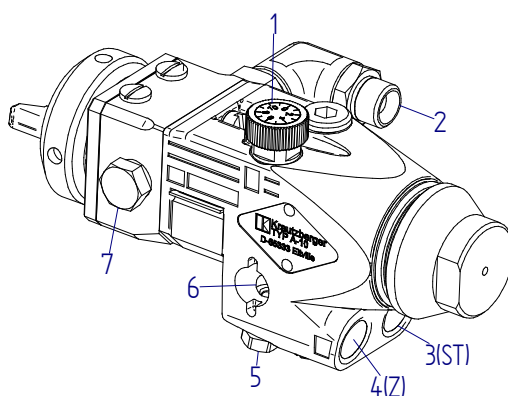

1	Jet regulator
2	Connection nipple coating substance G1/4" aG
3	Control air (St) G1/4" iG
4	Atomiser air (Z) G1/4" iG
5	Screws (fix retaining bolt)
6	Hole for retaining bolt
7	Circulation connection (optional)

- Push the automatic spray gun with borehole (8) over a retaining bolt and fix in place using screws (5)

⚠ VIBRATION AND RECOIL EFFECTS CAN OCCUR DURING THE OPERATION OF THE Automatic SPRAY GUN. ENSURE THAT THE GUN IS ADEQUATELY SECURED IN PLACE.

- Connect control air to item 3 ("ST")
- Connect atomiser air to item 4 ("Z")
- Material feed to item 2 ("M"); in the case of circulation second connection to item 7

⚠ IF THE CONTROL AIR AND ATOMISER AIR CONNECTIONS ARE INTERCHANGED, THIS CAN RESULT IN ACCIDENTAL OPERATION OF THE AUTOMATIC SPRAY GUN.

⚠ ONLY USE HOSES WHICH CAN RELIABLY WITHSTAND THE PRESSURES AND MECHANICAL AND CHEMICAL LOADS DURING OPERATION!

Start-up

- Switch on compressed air feed
- Switch on pump
- Point automatic spray gun at a test surface
- Start spraying process by switching on the control air
- Adjust the spray profile

Spray profile adjustment

i A wide range of air and material nozzles in various sizes are available to perform widely differing coating tasks. There are two different nozzle families:
“Slot air”
“Horn air”

Take the following steps to adjust the spray profile:

- Regulation of atomiser air pressure
- with jet regulator
- Pressure of the coating material
- Choosing the suitable nozzle size

i Excessive air pressure not only leads to unnecessarily high air consumption but also generates heavy misting of the coating substance. It is advisable to first adjust the spray profile by adjusting the air and coating material pressure. If this does not produce a satisfactory profile, you should experiment with different nozzle sizes.

Operational interruptions, cleaning

! ALWAYS ADHERE TO THE INSTRUCTIONS IN THE SAFETY DATA SHEET OF THE DETERGENT MANUFACTURER. DETERGENTS CAN BE HARMFUL TO HEALTH AND EASILY FLAMMABLE!
 THE AUTOMATIC SPRAY GUN SHOULD NEVER BE COMPLETELY IMMERSSED IN DETERGENT! THIS COULD DESTROY THE GASKETS AND RINSE OUT THE LUBRICANT!

- Switch off the control air to terminate the spraying process
- Interrupt coating material feed (switch off pump or pressure container)

- Clean automatic spray gun (in place of the coating substance, spray a suitable detergent until it emerges clear and without soiling).
- Interrupt detergent feed
- Briefly switch on control air feed to blow out detergent residues.
- Interrupt compressed air feed
- Clean externally using a cloth soaked in detergent.

Maintenance

i Please see our catalogue for accessories as well as available air nozzles, material nozzles and needles.

The catalogue is available on the Internet in PDF format (www.krautzberger.com).

! ALL MAINTENANCE WORK MUST BE PERFORMED BY SUITABLY QUALIFIED PERSONNEL!

BEFORE ALL MAINTENANCE WORK:

CLEAN SPRAY GUN, INTERRUPT COMPRESSED AIR FEED AND COATING SUBSTANCE FEED; DISSIPATE ANY RESIDUAL PRESSURE BY OPERATING THE AUTOMATIC SPRAY GUN

i Check wearing parts like gaskets, nozzles and needles at regular intervals. The level of wear depends on the abrasiveness of the coating substance used. Escaping air and coating substance as well as the deterioration of the spray profile are signs that parts are worn.

Do not clean material and air nozzles using hard, sharp-edged objects (for cleaning of the nozzles,

we recommend our brush set).

The wearing parts are shown in the Appendix.

- Lightly grease sliding parts. We advise you to use Krautzberger special grease for parts that need greasing. This grease is available in 250g cans.

- Always replace material nozzle and material needle together
- Following assembly, ensure that all parts are firmly tightened/connected
- Check moving parts for smooth motion

Technical data

Pressure, temperature

Max material pressure	10 MPa	100 bar
Max. material temperature:	50 °C	
Max. atomiser air pressure	0,6 MPa	6 bar
Min./Max. control air pressure:	0,8 MPa	8 bar
Max. compressed air temperature:	50 °C	

Connections

Coating substance:	G1/4a
Atomiser air	G1/4i
Control air	G1/4i

Weight

ca. 930 g

Noise level

(nozzle-dependent) 60 bis 90 dB (A)

Spare parts drawing

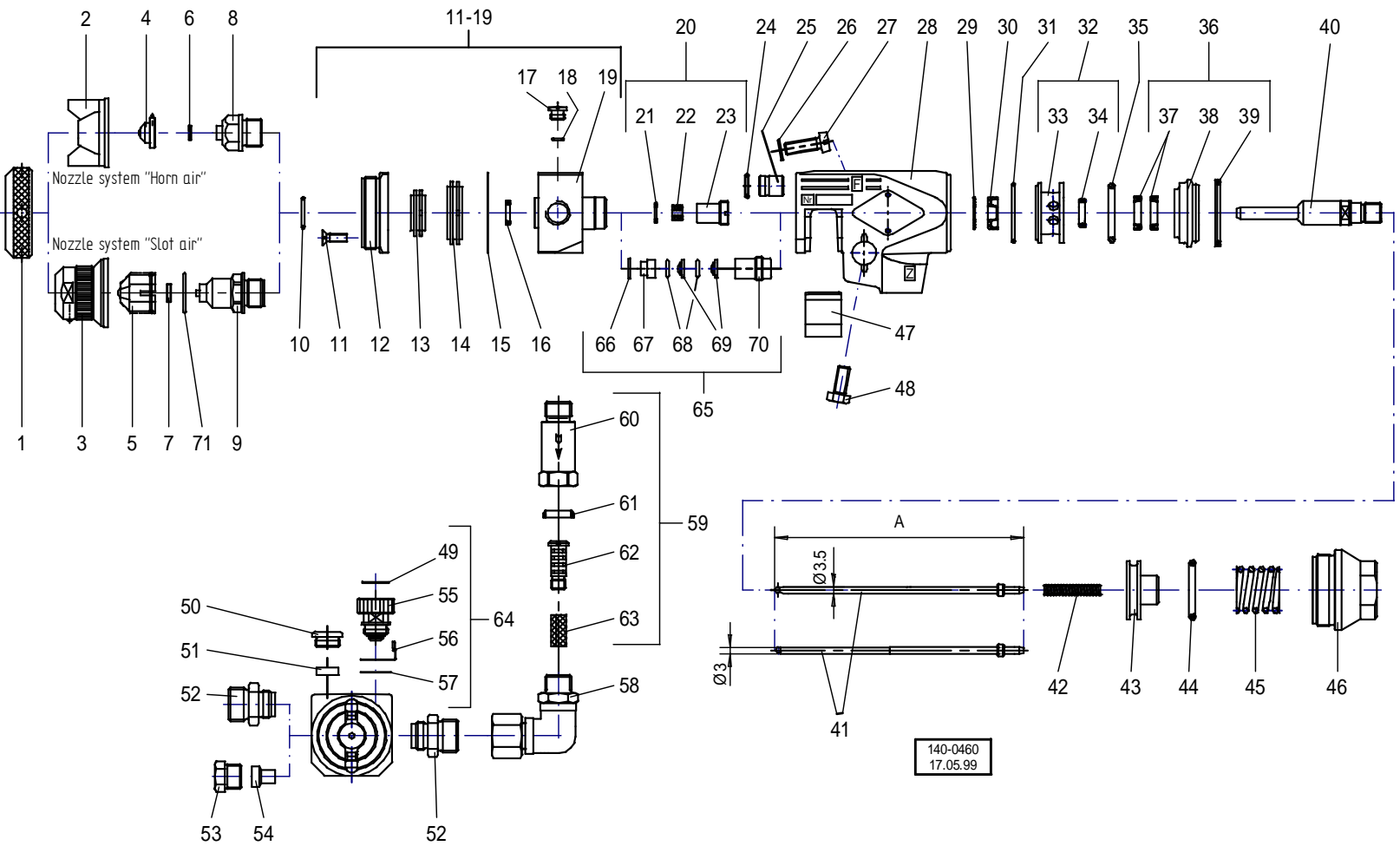

Spare parts list

item.	Order-No.	Designation	item.	Order-No.	Designation
1	040-0829	Clamping nut	46	040-3856	Locking screw
2	060-0743	Air nozzle	47	040-1604	Cover clamp
3	060-0294	Air nozzle	48	030-0272	Screw (2 pcs)
** 4	050-....	Material nozzle (incl. Item. 6)	49	040-0212	Scale disk
** 5	050-....	Material nozzle (incl. Item. 7, 71)	50	040-1510	Locking screw
* 6	010-0057	Gasket	51	010-0327	Gasket
* 7	010-0047	Gasket	52	040-0421	Connection nipple (1 or 2 pcs)
8	080-2948	Valve seat screw (incl. Item. 10)	53	040-4064	Locking screw
9	080-2946	Valve seat screw (incl. Item. 10)	54	040-4094	Drain plug
* 10	010-0046	Gasket	55	080-0485	Jet regulator
11-19	080-0613	Head section, complete	56	020-0024	Detent spring
11	030-3298	Screw (4 pcs)	57	040-1511	Disk
12	040-0262	Head section (incl. Item. 13, 14)	58	080-2680	Connecting angle
13	040-2711	Ring	59	080-....	Material filter kpl.
14	040-2710	Ring	** 60	040-4142	Mesh housing
* 15	010-0362	Gasket	61	010-0045	Gasket
* 16	080-0176	Gasket	* 62	040-4141	Screw
17	040-1205	Screw (2 pcs)	*** 63	030-1411-:::17	Filtermesh
* 18	010-0032	Gasket (2 pcs)	** 64	080-0987	Jet regulator, cpl.
19	040-0264	Transition piece	65	010-0810	Needle packing, cpl. (Needle-ø 3)
20	010-0694	Needle packing cpl. (needle-ø 3,5)	66	010-0182	Gasket
* 21	010-0184	Gasket	67	040-4679	Needle guide
* 22	010-0364	Gasket	68	010-0043	Gasket (2 pcs)
23	040-2140	Sealing screw	69	010-0044	Gasket (2 pcs)
* 24	010-0188	Gasket (2 pcs)	70	040-4678	Sealing screw
25	040-1508	Centering pipe (2 pcs)	71	040-1055	Lock washer
26	030-0706	Safety disk		010-0783	Gasket set
27	030-0179	Screw			
28	080-0050	Main element, cpl			
29	040-1512	Disk			
* 30	010-0178	Gasket			
* 31	010-0213	Gasket			
32	040-1514	Valve housing, cpl.			
33	040-1515	Valve housing			
* 34	010-0179	Gasket			
* 35	010-0546	Gasket			
36	080-0486	Valve shaft guide			
* 37	010-0190	Gasket (2 pcs)			
38	040-1516	Valve shaft guide			
* 39	010-0180	Gasket			
40	040-3854	Valve shaft pipe			
** 41	070-1970	Material needle, A=123; ø 3,5 (nozzle system „slot air“)			
** 41	070-1973	Material needle, A=111; ø 3,5			
** 41	070-2376	Material needle, A=111; ø 3			
42	020-0029	Spring			
43	040-3855	Shaft ring			
44	010-0546	Gasket			
45	020-0176	Spring			

* contained in the gasket set

** Please state type and size when ordering

*** Available mesh sizes: 0,06 - 0,07 - 0,08 - 0,09 - 0,15 - 0,2 - 0,3

Please state the type of your nozzle system (flat or horn) when ordering parts.