



MIXING – DOSING - BATCHING

EASY – MIX - SYSTEME



nearly each kind of application are possible
broad spectrum of materials, including solvent borne, waterborne epoxies,
and acid catalyzed materials

- use know how -



EASY_MIX based of SIMATIC Technology

Linz-Technology



Rainer Linz Oberflächentechnik GmbH

Linzer Strasse 1, A-3003 Gablitz

Phone: +43 2231 65193-0

Fax: +43 2231 65193-14

Mail: office@linz-ambh.com

Mobil: +43 664 3004704

<http://www.linz-ambh.com>

Vertriebsbüro Deutschland

Kirchplatz 3

D-74357 Bönnigheim

sales.de@linz-ambh.com

+49 151 27183516

Easy Mix system based of SIMATIC TECHNOLOGY
operating by Touch or using PN/PN coupler
and operate from your PLC

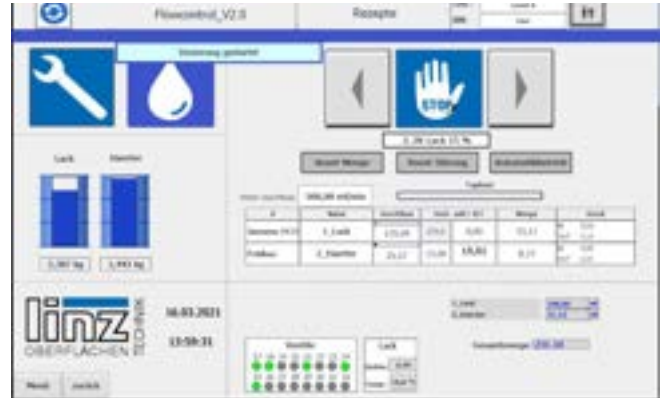

support from beginning
SERVICE – UPDATE BY VPN REMOTE CONTROL

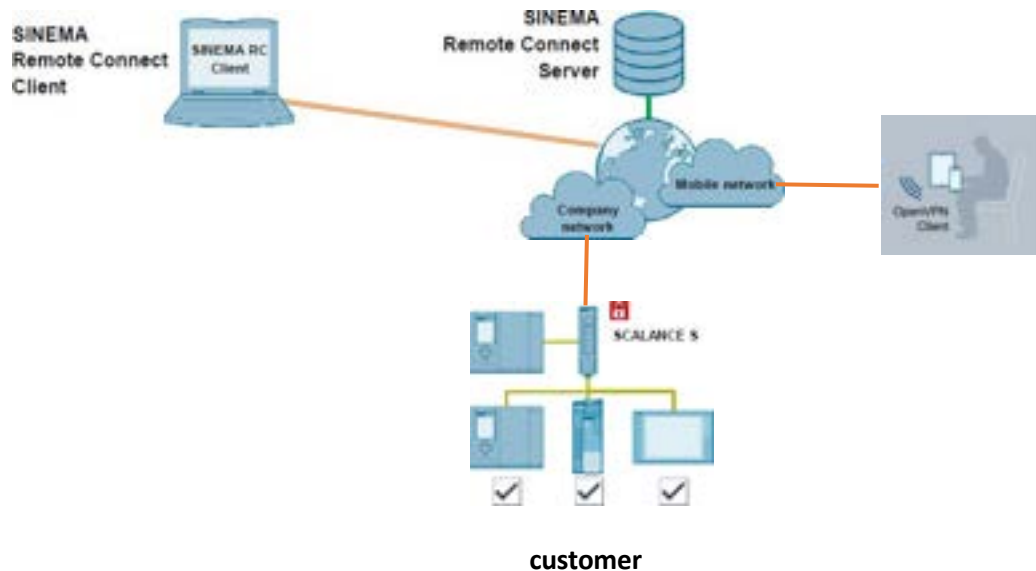

**EASY MIX P15 3 component system
Airless / Airmix**



Gun cleaner – easy clean



Rainer Linz Oberflächentechnik GmbH

Linzer Strasse 1, A-3003 Gablitz

Phone: +43 2231 65193-0

Fax: +43 2231 65193-14

Mail: office@linz-ambh.com

Mobil: +43 664 3004704

<http://www.linz-ambh.com>

Vertriebsbüro Deutschland

Kirchplatz 3

D-74357 Bönnigheim

sales.de@linz-ambh.com

+49 151 27183516

TECHNICAL EQUIPMENT, OPTIONS

- **Software:** FlowControl useable for each application configuration
- **operating:** 1 – 4 components
- **pressure:** 1-250 bar
- **flow measurement:** Coriolis flowmeter / Gear flowmeter / inductive flowmeter
- **supply system:** piston pump, diaphragm pump, eccentric pump, piston dispenser
- **mixing system:** injection system, device control
- **ratio:** 0,1:1 - 1 : 1
- **accuracy:** depending from equipment and material 0,5 % - xxxx

- the use of valves and assemblies will be adapted to customer requirements

MEASURING DEVICES flow rate adaptable to your application (0,01 – xxx kg/min.)

- Coriolis flowmeter
- Inductive flowmeter

- Gear flowmeter



Rainer Linz Oberflächentechnik GmbH

Linzer Strasse 1, A-3003 Gablitz
 Phone: +43 2231 65191-0
 Fax: +43 2231 65193-14
 Mail: office@linz-ambh.com
 Mobil: +43 664 3004704
<http://www.linz-ambh.com>

Vertriebsbüro Deutschland
 Kirchplatz 3
 D-74357 Bönnigheim
sales.de@linz-ambh.com
 +49 151 27183516

dispense devices

gear pumps:

different types and flowrates, adapted to your application

- ADLC coated (easy cleaning)
- TITAN coated (abrasive products)
- stainless steel
- different types of gears
- servo drive management

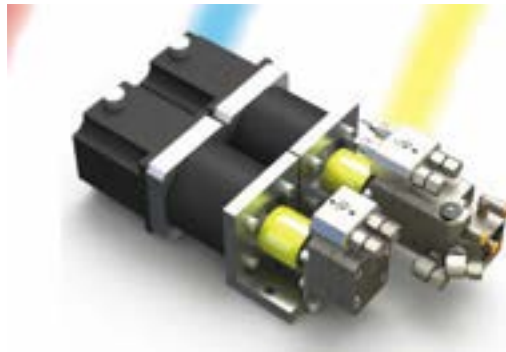

eccentric pumps:

different types and flowrates, adapted to your application

- stainless steel
- different stators



Rainer Linz Oberflächentechnik GmbH

Linzer Strasse 1, A-3003 Gablitz

Phone: +43 2231 65193-0

Fax: +43 2231 65193-14

Mail: office@linz-ambh.com

Mobil: +43 664 3004704

<http://www.linz-ambh.com>

Vertriebsbüro Deutschland

Kirchplatz 3

D-74357 Bönnigheim

sales.de@linz-ambh.com

+49 151 27183516

eccentric pumps: modules for high-performance dosing-systems

for bonding, sealing, filling, casting, process-controlled dosing

- flow volume: 0,003 ml/min - 240,0 ml/min



Rainer Linz Oberflächentechnik GmbH

Linzer Strasse 1, A-3003 Gablitz

Phone: +43 2231 65193-0

Fax: +43 2231 65193-14

Mail: office@linz-ambh.com

Mobil: +43 664 3004704

<http://www.linz-ambh.com>

Vertriebsbüro Deutschland

Kirchplatz 3

D-74357 Bönnigheim

sales.de@linz-ambh.com

+49 151 27183516

2 component Airless intern mix system ALP

(for products with short pot life time)

airless handgun



airless automatic gun

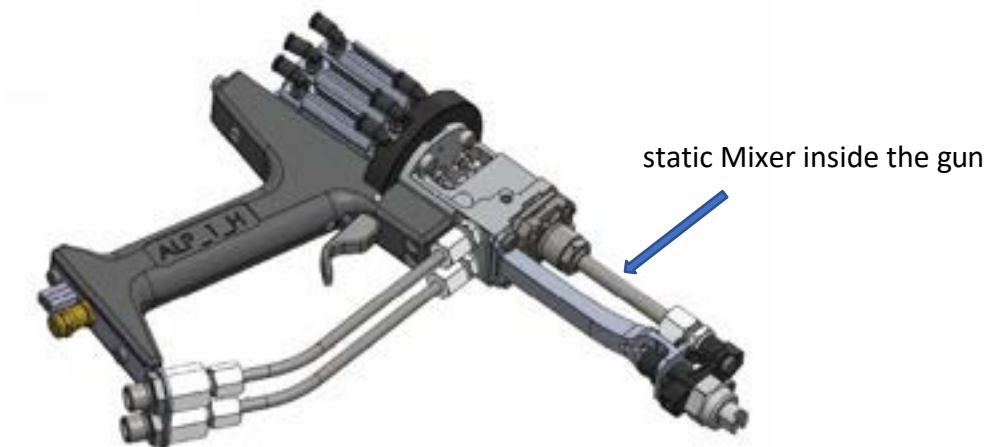

- ALP gun system in combination with our FlowControl system
- max. high pressure 150 bar
- standard airless nozzle tips
- gun triggering by capacitive sensor
- A + B component can be activated in single mode



Rainer Linz Oberflächentechnik GmbH

Linzer Strasse 1, A-3003 Gablitz

Phone: +43 2231 65193-0

Fax: +43 2231 65193-14

Mail: office@linz-ambh.com

Mobil: +43 664 3004704

<http://www.linz-ambh.com>

Vertriebsbüro Deutschland

Kirchplatz 3

D-74357 Bönnigheim

sales.de@linz-ambh.com

+49 151 27183516

supply pumps easy mix

diaphragm pumps:

different types and flowrates, adapted to your application



- pneumatic pump, stainless steel
- sizes: G 3/8" - G 1/2" - G 1"

piston pumps:

different types and flowrates, adapted to your application



- classic piston pump systems
- bellows pumps for isocyanate

different

pressure tanks:

different sizes and quality, with stirrer and level control



Rainer Linz Oberflächentechnik GmbH

Linzer Strasse 1, A-3003 Gablitz

Phone: +43 2231 65193-0

Fax: +43 2231 65193-14

Mail: office@linz-ambh.com

Mobil: +43 664 3004704

<http://www.linz-ambh.com>

Vertriebsbüro Deutschland

Kirchplatz 3

D-74357 Bönnigheim

sales.de@linz-ambh.com

+49 151 27183516

spray application 2 component water-based glue

automatic spray



manual spray



piston dosing



Rainer Linz Oberflächentechnik GmbH

Linzer Strasse 1, A-3003 Gablitz

Phone: +43 2231 65193-0

Fax: +43 2231 65193-14

Mail: office@linz-ambh.com

Mobil: +43 664 3004704

<http://www.linz-ambh.com>

Vertriebsbüro Deutschland

Kirchplatz 3

D-74357 Bönnigheim

sales.de@linz-ambh.com

+49 151 27183516

spray application Airless electrostatic 2 component



automatic gun flush station after pot life



air assistant spray system

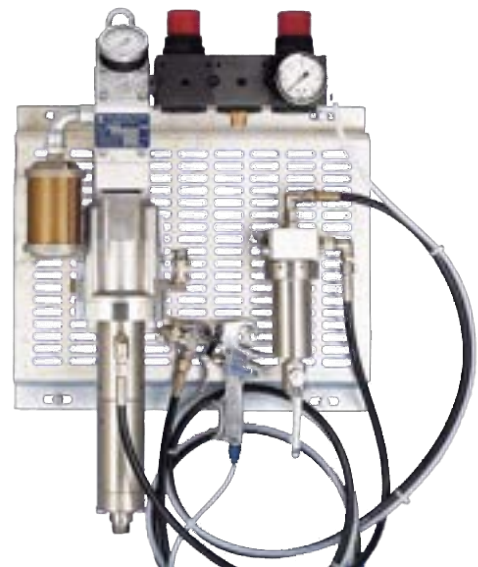

Rainer Linz Oberflächentechnik GmbH

Linzer Strasse 1, A-3003 Gablitz

Phone: +43 2231 65193-0

Fax: +43 2231 65193-14

Mail: office@linz-ambh.com

Mobil: +43 664 3004704

<http://www.linz-ambh.com>

Vertriebsbüro Deutschland

Kirchplatz 3

D-74357 Bönnigheim

sales.de@linz-ambh.com

+49 151 27183516

spray application automatic HVLP - 3 component

EASY MIX (recipe scanning)



dosing by gear pumps, measuring by coriolis system



**supply center diaphragm pumps
agitator, level control**



Rainer Linz Oberflächentechnik GmbH

Linzer Strasse 1, A-3003 Gablitz

Phone: +43 2231 65193-0

Fax: +43 2231 65193-14

Mail: office@linz-ambh.com

Mobil: +43 664 3004704

<http://www.linz-ambh.com>

Vertriebsbüro Deutschland

Kirchplatz 3

D-74357 Bönnigheim

sales.de@linz-ambh.com

+49 151 27183516

spray application automatic HVLP – 2 component plastic parts

main cabinet



Rainer Linz Oberflächentechnik GmbH

Linzer Strasse 1, A-3003 Gablitz

Phone: +43 2231 65193-0

Fax: +43 2231 65193-14

Mail: office@linz-ambh.com

Mobil: +43 664 3004704

<http://www.linz-ambh.com>

Vertriebsbüro Deutschland

Kirchplatz 3

D-74357 Bönnigheim

sales.de@linz-ambh.com

+49 151 27183516

metering and dispensing, single-component or multi-component materials

1 component glue dosing by gear pump

glue dosing line, controlled by Siemens S7



glue line

dosing pump 50 cc

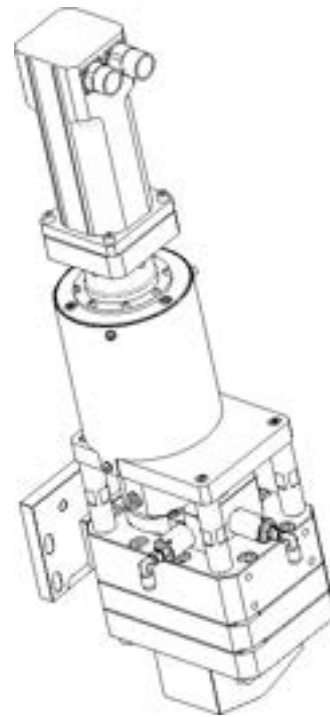

Rainer Linz Oberflächentechnik GmbH

Linzer Strasse 1, A-3003 Gablitz

Phone: +43 2231 65193-0

Fax: +43 2231 65193-14

Mail: office@linz-ambh.com

Mobil: +43 664 3004704

<http://www.linz-ambh.com>

Vertriebsbüro Deutschland

Kirchplatz 3

D-74357 Bönnigheim

sales.de@linz-ambh.com

+49 151 27183516

application 2 component PU glue

2 component PU glue gun MP_10H



2 component PU glu automatic gun MP_10A



Gear pump for RAM station



dosing station for low viscosity material



Rainer Linz Oberflächentechnik GmbH

Linzer Strasse 1, A-3003 Gablitz

Phone: +43 2231 65193-0

Fax: +43 2231 65193-14

Mail: office@linz-ambh.com

Mobil: +43 664 3004704

<http://www.linz-ambh.com>

Vertriebsbüro Deutschland

Kirchplatz 3

D-74357 Bönnigheim

sales.de@linz-ambh.com

+49 151 27183516

2 component glue dosing - roll coater application



Rainer Linz Oberflächentechnik GmbH

Linzer Strasse 1, A-3003 Gablitz

Phone: +43 2231 65193-0

Fax: +43 2231 65193-14

Mail: office@linz-ambh.com

Mobil: +43 664 3004704

<http://www.linz-ambh.com>

Vertriebsbüro Deutschland

Kirchplatz 3

D-74357 Bönnigheim

sales.de@linz-ambh.com

+49 151 27183516

Glue 2 component application - EASY MIX -



Rainer Linz Oberflächentechnik GmbH

Linzer Strasse 1, A-3003 Gablitz

Phone: +43 2231 65191-0

Fax: +43 2231 65193-14

Mail: office@linz-ambh.com

Mobil: +43 664 3004704

<http://www.linz-ambh.com>

Vertriebsbüro Deutschland

Kirchplatz 3

D-74357 Bönnigheim

sales.de@linz-ambh.com

+49 151 27183516

Equipment for mixing and dosing applications

change over valves high pressure Serie RIB
different combination possible

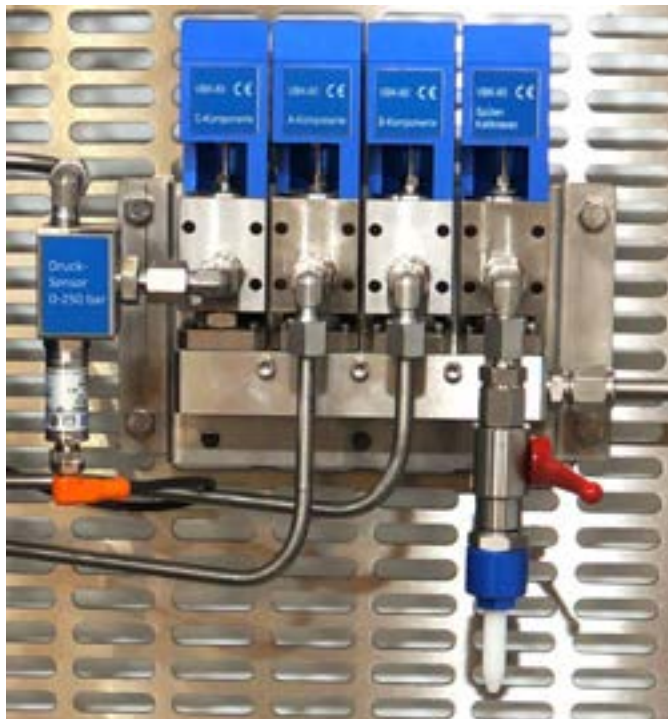

Multi-mixing head MB-70



multi mixing head MP-07
7 Color Ports

injection / dosing valves
with different nozzle equipment

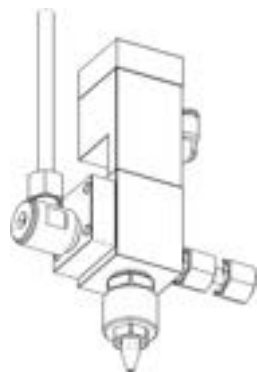

different nozzle sizes
and design



different static mixer



Rainer Linz Oberflächentechnik GmbH

Linzer Strasse 1, A-3003 Gablitz

Phone: +43 2231 65193-0

Fax: +43 2231 65193-14

Mail: office@linz-ambh.com

Mobil: +43 664 3004704

<http://www.linz-ambh.com>

Vertriebsbüro Deutschland

Kirchplatz 3

D-74357 Bönnigheim

sales.de@linz-ambh.com

+49 151 27183516

**mixing bloc VBK-10
(different combination possible)
single channel bloc system**

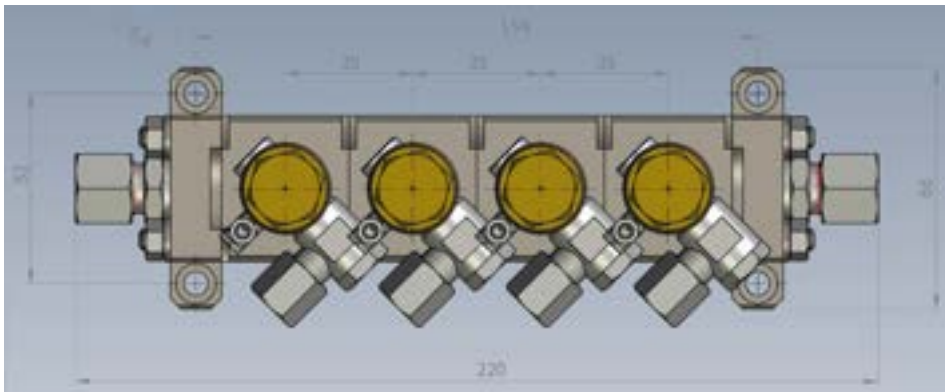

→ static mixer

2 C mixing block (paint supply port selectable)

- compact design and great performance
- excellent rinsing properties
- with not-return valve on the components
- selectable with solvent connection for A + B components
- material pressure max. 5 bar (depending on the valve)
- valve seats and valve needles in stainless steel or hard metal
- different valve seat diameter

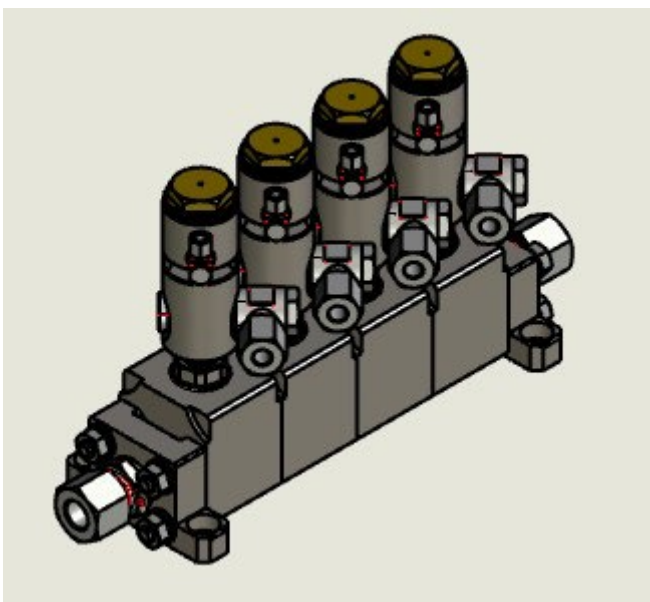

Rainer Linz Oberflächentechnik GmbH

Linzer Strasse 1, A-3003 Gablitz

Phone: +43 2231 65193-0

Fax: +43 2231 65193-14

Mail: office@linz-ambh.com

Mobil: +43 664 3004704

<http://www.linz-ambh.com>

Vertriebsbüro Deutschland

Kirchplatz 3

D-74357 Bönnigheim

sales.de@linz-ambh.com

+49 151 27183516

paint mixing bloc VBK-08
2 channel bloc version
VBK-08

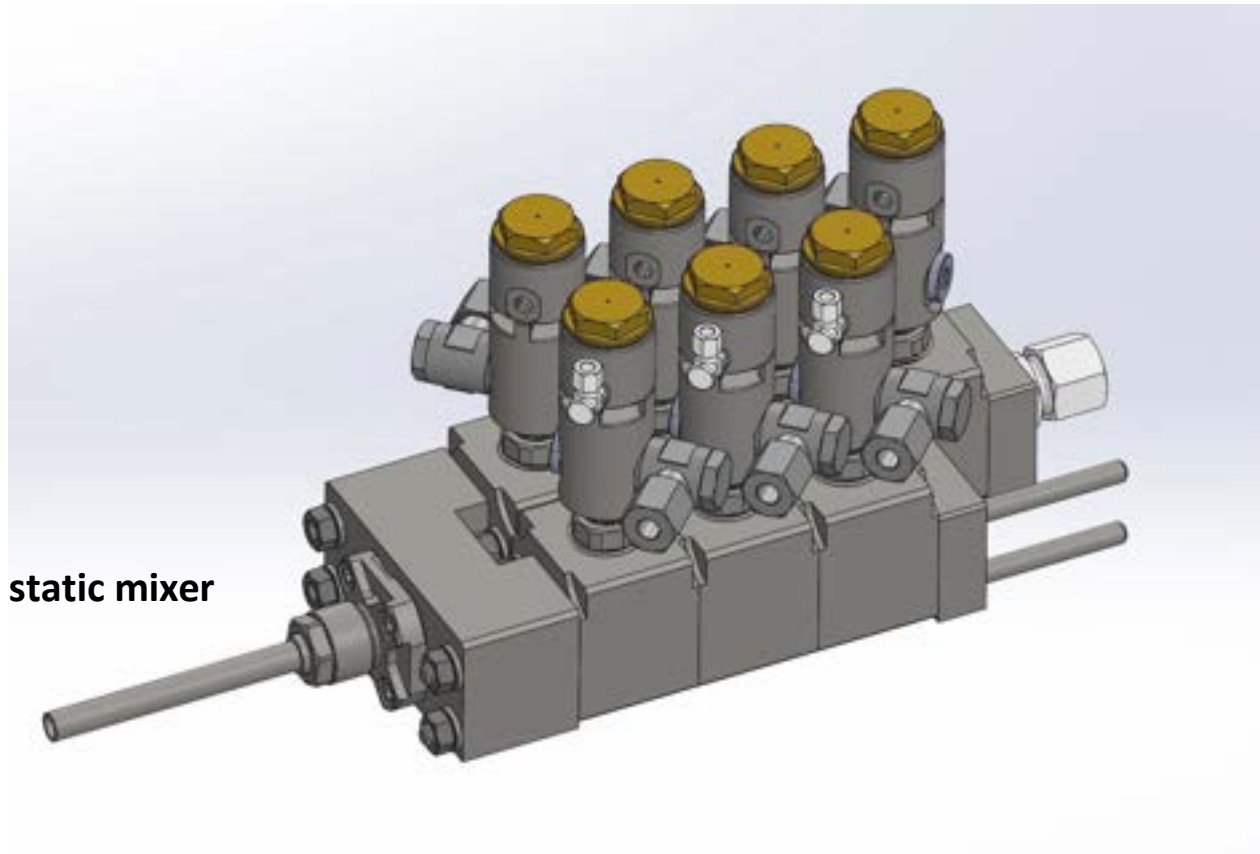

2 C mixing bloc (number of valves selectable)

- compact design and great performance
- excellent rinsing properties
- with not-return valve on the components
- selectable with solvent connection for A + B components
- material pressure max. 5 bar (depending on the valve)
- valve seats and valve needles in stainless steel or hard metal
- different valve seat diameter



Rainer Linz Oberflächentechnik GmbH

Linzer Strasse 1, A-3003 Gablitz

Phone: +43 2231 65193-0

Fax: +43 2231 65193-14

Mail: office@linz-ambh.com

Mobil: +43 664 3004704

<http://www.linz-ambh.com>

Vertriebsbüro Deutschland

Kirchplatz 3

D-74357 Bönnigheim

sales.de@linz-ambh.com

+49 151 27183516

NOTES:

.....

.....

.....

.....

.....

.....

.....

.....

.....

.....

.....

.....

.....

.....

.....

.....

.....

.....

.....

.....

.....

